

GL16 LED Pattern Projection Cutting Light



Product Introduction:

The GL16 series of high-definition LED pattern and gobo projection lights boasts a collaborative design effort between China and Europe, embodying cutting-edge technology. Crafted primarily from aluminum alloy, the GL16 light's main structure undergoes an oxidation process resulting in a matte black finish, ensuring both durability and a stylish aesthetic. It utilizes high-grade LED as the light source, delivering exceptional luminous efficiency, remarkable stability, and an ultra-long lifespan. The optical part of the GL16 features a patented variable optical imaging system. The lens boasts an impressive resolution capable of discerning pixel units as small as 2 microns, producing highly uniform light spots devoid of color fringing (such as blue and yellow). Furthermore, it achieves continuous linear zoom across the entire angle range. Rotary adjustment damping-design front lenses facilitate smooth zoom and focusing operations without compromising luminous efficiency during adjustments. Equipped with removable lens part, the GL16 allows quick change gobo and securely holds the gobo plate in place. The light also integrates a four-blade structure for profile-cutting, enabling the creation of diverse light spot shapes.

The dedicated build-in module offers continuous brightness control, adjustable from 0 to 100%, providing unparalleled versatility.

The GL16 lights are ideally suited for a wide array of projection lighting applications, including stage performances, cultural and tourist landscapes, film and video production, commercial photography, museums, art galleries, and beyond.

Specification and Parameter:

- Light source: high-grade LED
- Dimming: 0~100% continuous dimming, knob operation
- Optical system: variable optical imaging system, zoom-able or fixed angle
- Optical performance: ultra high resolution, discerning pixel units as small as 2 microns, chromatic aberration elimination
- Projection direction: direct
- Power supply: DC12V, 1A
- Installation: Embedded installation, drilled with a hole diameter of 45mm
- Working ambient temperature: -20°C ~ 40°C
- Net weight: ≈ 0.25 kg, the weight of different models will vary
- Accessories: safety rope, DC power adapter
- Outer packaging size: 310×130×130 mm

Projection Effect Demonstration:

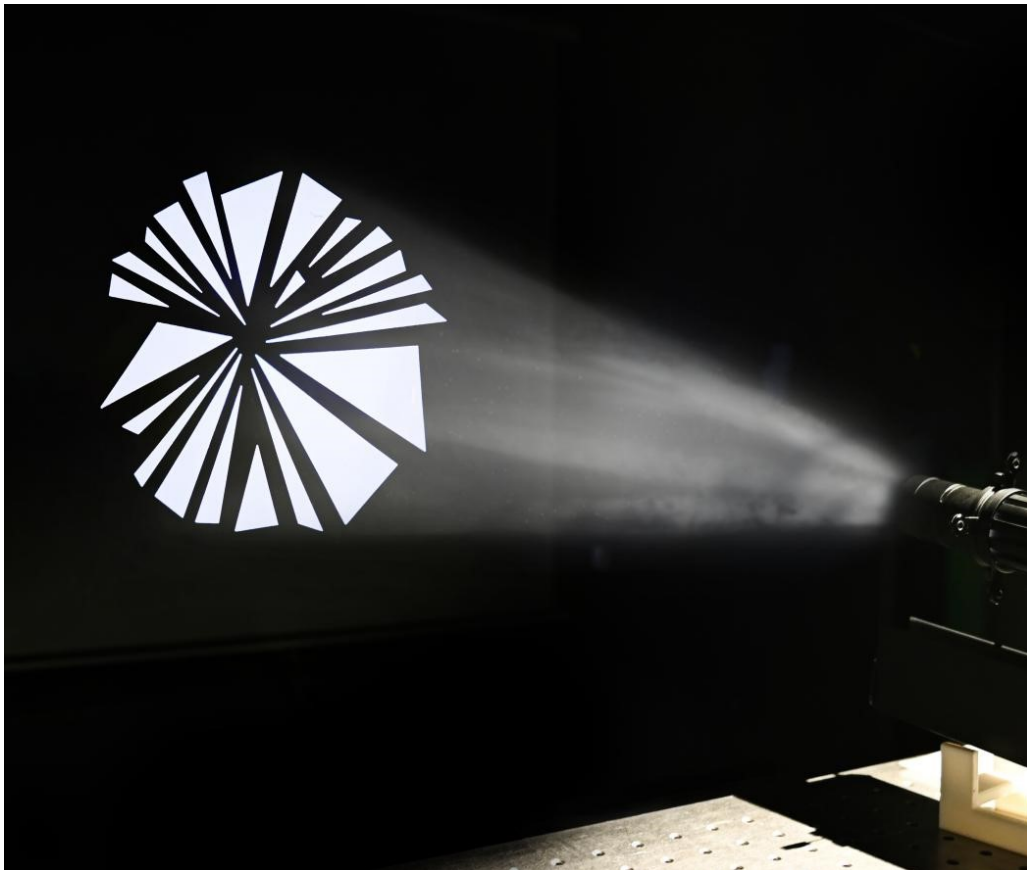

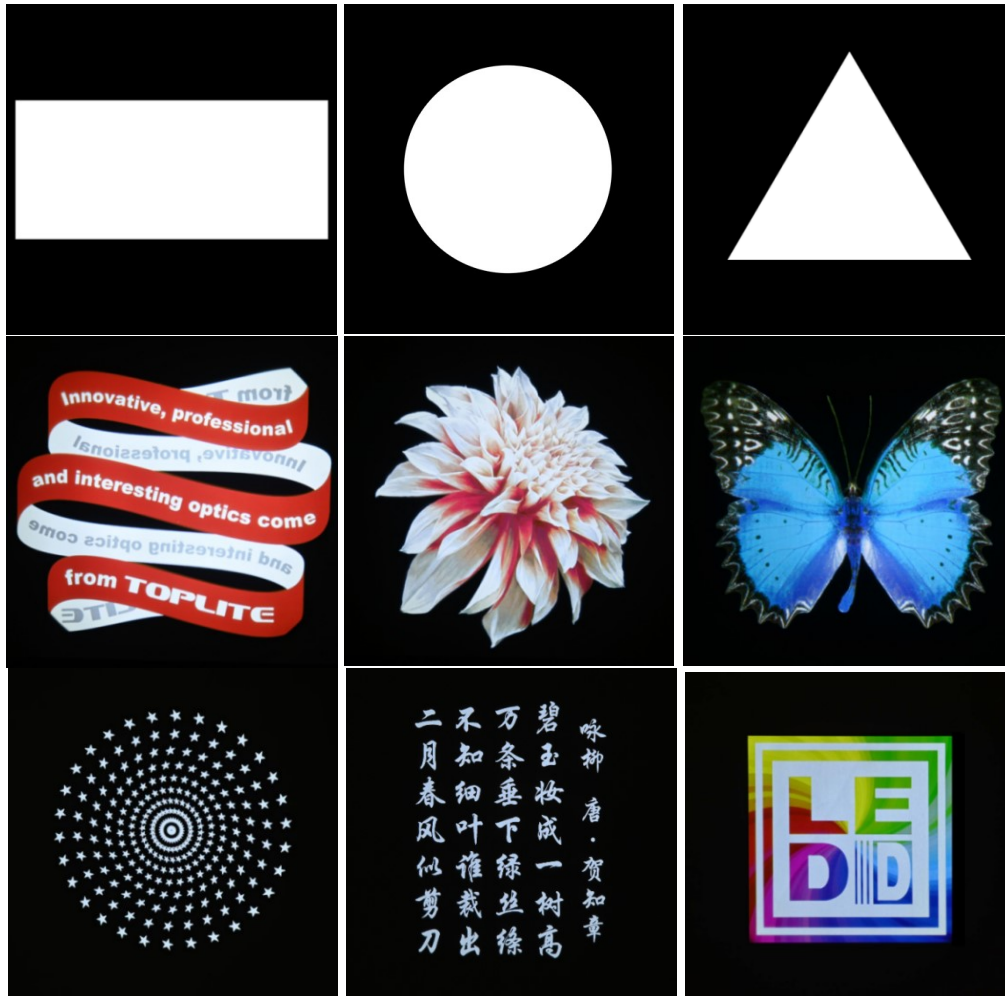

Model Selection List:

No.	Model No.	Zoom range	Gobo	Projection Ratio	Outline Dimension
1	GL16Z1631Q	16~31°	≤ 14 mm	1 : 0.28~0.56	250×100×100mm
2	GL16Z3048Q	30~48°	≤ 14 mm	1 : 0.53~0.89	230×100×100mm

Model Instruction: Recessed



Model No.	Beam Angle	Installation	Power	CCT	CRI	Color
GL16	Zoom □ Z + range Fixed □ F + angle	Rail□G Magnetic□C Hang□D Recessed□Q	10W □	3000K□C30 4000K□C40 5700K□C57 Variable□DS	CRI70□ R70CRI90□ R90CRI95□R95	W□White B□Black C□Customized

Example: GL16-Z1631-Q-10W-C30-R70-B

- Beam angle: zoom-able, from 16° to 31°
- Installation: Embedded into mounting surface where needs to be drilled with a hole diameter of 45mm

diameter of 45mm

- Power: 10 W
- CCT: 3000 K
- CRI: Ra70
- Color: Black

Light Beam and Test Data:

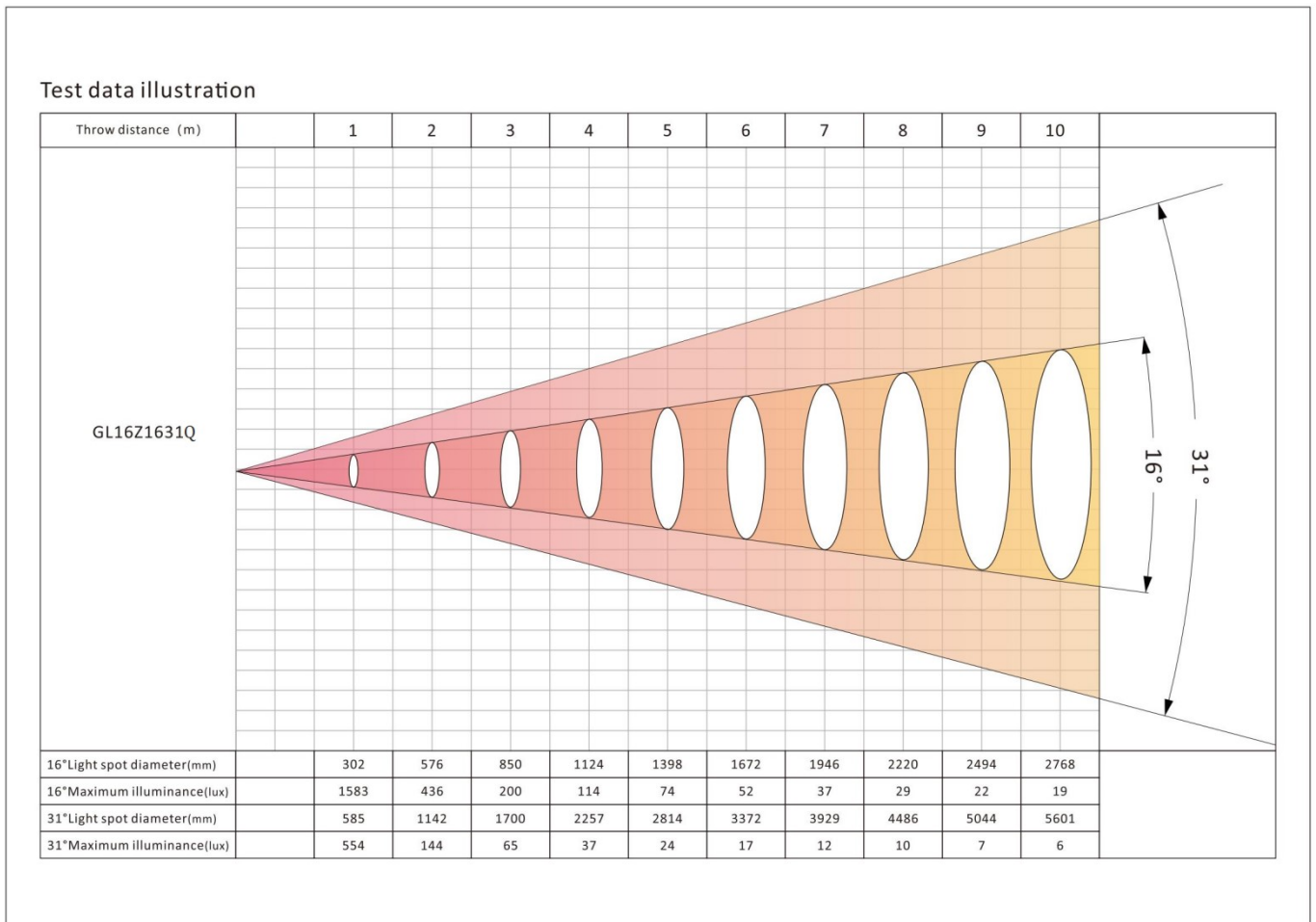

Test data illustration

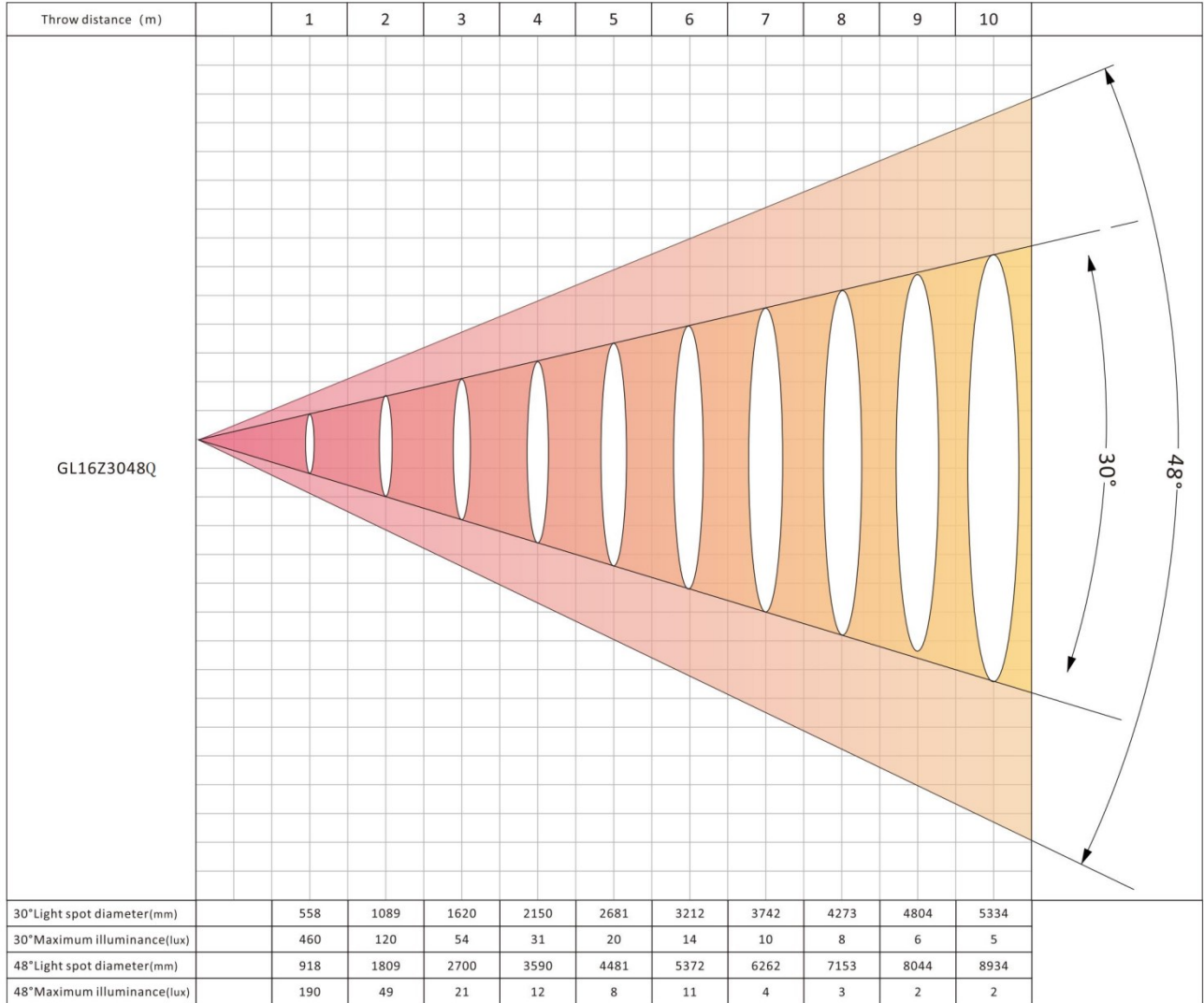

Outline Mechanical Dimension:

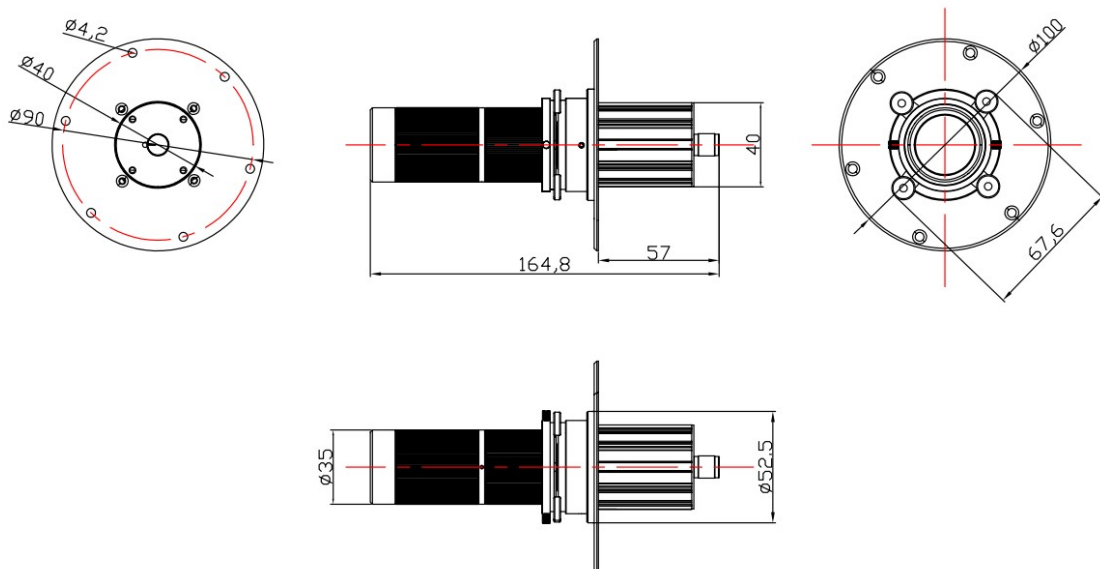

Installation and Adjustment Instruction:

Use bolts to fix the lamp to the surface where it needs to be embedded through the mounting holes.

Rotate the lens to zoom or focus

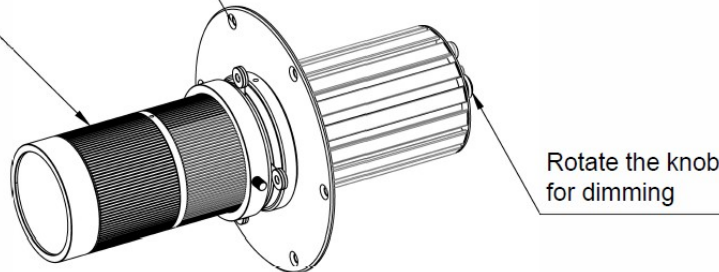

Rotate the knob for dimming

Step2, take the spring pressing plate off and replace the gobo

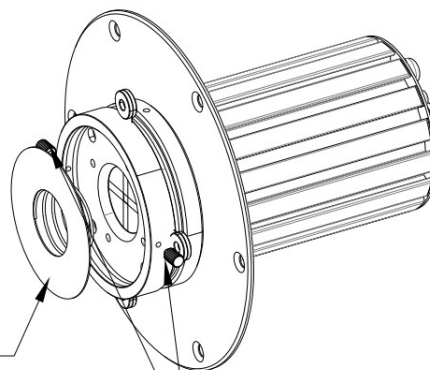

Step1, Loosen the screws

Precautions:

- This product should be avoided from being used in high temperature environments for long periods of time.
- The protection level designed for this product is IP20. Use in environments beyond this range should be avoided.
- This product cannot be directly connected to mains power without a driver.
- Use within a safe voltage range, otherwise it will affect the product life and even cause damage.
- The power supply should be cut off before installation to avoid electric shock injury.
- This product cannot be cleaned or disassembled directly.
- Because our company's products are constantly being improved, the design, specifications or instructions are subject to change without prior notice.