



SPECIFICATION

P/N: MED 3X42AWG+1PX34AWG

Customer File NO.

Customer Signed by.

SHS TECHNOLOGY CO.,LTD
苏州尚虹鑫电子科技有限公司

APPROVED	CHECK	DRAWING
 <p>徐磊 2024.4.28</p>	 <p>徐磊 2024.4.28</p>	 <p>王思哲 2024.4.28</p>

1. Scope

This specification covers multi micro-coaxial cable for medical equipment.

2. Construction and Material

Item		Unit	Specified Value	
Core Number		-	3	1P
Conductor	Size	AWG	42	34
	Material	-	Silver plated copper alloy	Tinned copper
	Stranding	No./mm	7/0.025	7/0.06
Insulation	Material	-	Fluoropolymer	Fluoropolymer
	Color	-	Black,Red,Brown	Yellow,Blue
	Thickness	mm	0.04	0.04
	Diameter	mm	0.155	0.27
Twisted	Construction	-	-	Blue/Yellow
Cabling		-	See Fig.1	
Spiral Shield	Type	-	Wrap	
	Material	-	Tinned copper wire	
	Coverage	%	Min.95	
Jacket	Material	-	Fluoropolymer(Color: Black)	
	Thickness	mm	0.11	
	Diameter	mm	1.00±0.08	

* Add the filler to make the cable round if necessary.

3. Electrical Properties

Item	Unit	Specified Value	
		A:42WG	B:34AWG
Conductor Resistance (@ 20°C)	Ω/km	Max. 7300	Max.900
Insulation resistance (@ 20°C)	MΩ -km	Min. 1,000	
Dielectric Strength ¹⁾	-	To withstand A.C. 500V for 1min	
Capacitance (@ 1kHz)	pF/m	-	-
Impedance (@ TDR)	Ω	-	75±10

Note 1): Applied between each conductor.

4. Package

- 1). Unit length : According cumtomer requirement.
- 2). Package: Coiled into carton box

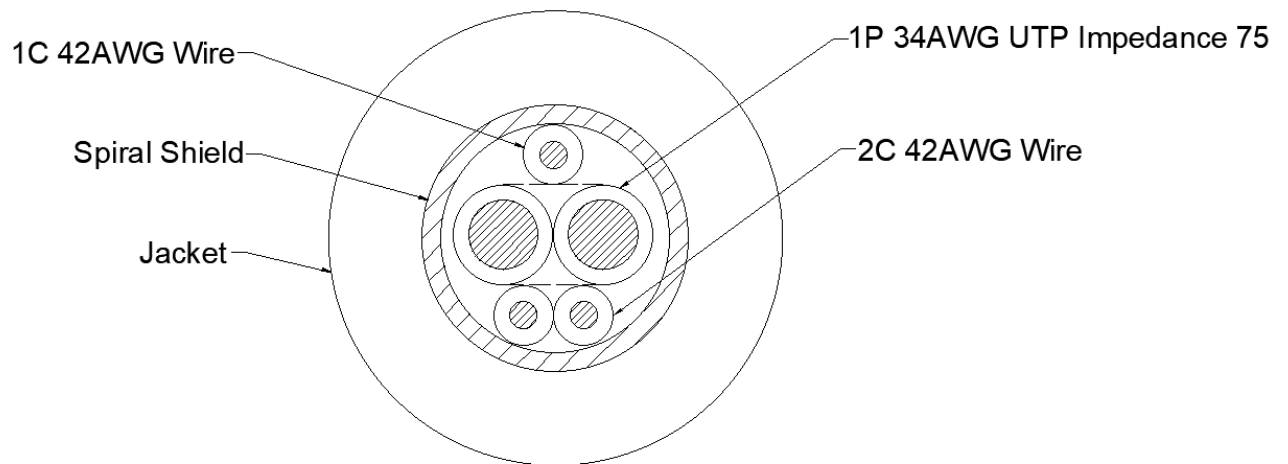

Fig.1 Cross section of cable

REVISION RECORD

Rev. No	Issue date	Item	DWN	CHK	APVD
1	4/28/2024	First released	Carter.W	Lester.X	Lester.X