

SPECIFICATION

MED 34X38AWG(SPC) PVC

Customer File NO. _____

Customer Signed by. _____

SUZHOU SHS TECHNOLOGY CO.,LTD

苏州尚虹鑫电子科技有限公司

APVD	CHK	DWN
Lester.Xu	Lester.Xu	Cater.Wang

(From DE-2001-01 Rev.1)

1. Scope

This specification covers multi micro-coaxial cable for medical device.

2. Construction and Material

Item		Unit	Specified Value
Core Number		-	34
Conductor	AWG Size	-	38
	Material	-	Silver plated copper
	Stranding	No./mm	7/0.04
	Diameter	mm	0.12
Insulation	Material	-	Fluoropolymer (Color: Green)
	Thickness	mm	0.10
	Diameter	mm	0.32
Spiral Shield	Type	-	Wrap
	Material	-	Silver plated copper alloy
	Strand	mm	0.03
Jacket	Material	-	Fluoropolymer (Color: See Table.1)
	Thickness	mm	0.075
	Diameter	mm	0.53
Cabling		-	See Fig.1
Binder Tape	Material	-	PTFE
Braid Shield	Material	-	Tinned annealed copper
	Strand (Nom.)	mm	0.08
	Coverage	%	Nom.85
Sheath	Material	-	Medical PVC (Color: Black)
	Thickness	mm	0.80
	Diameter	mm	6.00±0.20

3. Electrical Properties

Item	Unit	Specified Value
Conductor Resistance (@ 20°C)	Ω/km	Max. 3,000
Insulation resistance (@ 20°C)	MΩ -km	Min. 1,000
Dielectric Strength ¹⁾	-	To withstand A.C. 500V for 1min
Capacitance (@ 1kHz)	pF/m	95±10
Impedance (@ TDR)	Ω	Nom. 50

Note 1): Applied between conductor and spiral shield.

4. Package

- 1). Unit length : According cumtomer requirement.
- 2). Package: Coiled into plastic bag and then packed into carton box

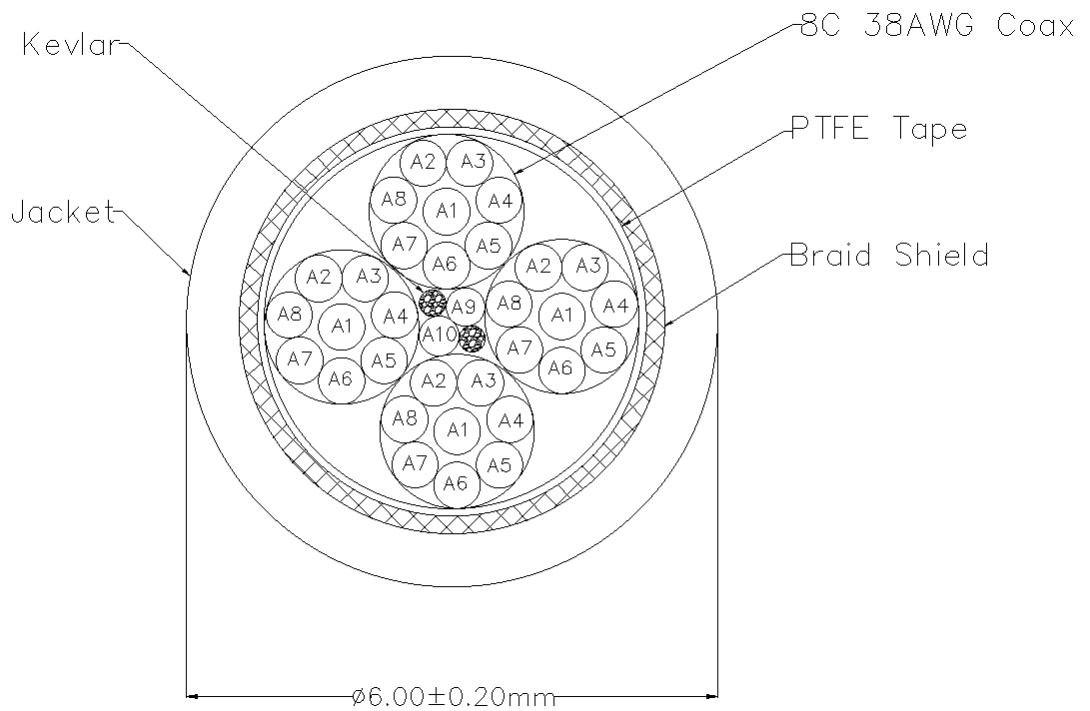

Fig.1 Cross section of cable

Table.1 Color of each wire

Unit No.	Color	Unit No.	Color
A1	Black	A6	Green
A2	Brown	A7	Blue
A3	Red	A8	Violet
A4	Orange	A9	Black
A5	Yellow	A10	Brown

REVISION RECORD

Rev. No	Issue date	Item	DWN	CHK	APVD
1	12/10/2021	First Released	Carter.Wang	Lester.Xu	Lester.Xu

Mail: leo.zhou@inspeed-cable.com

Add: #37,ZhenTai Road,TaiPing Town,SuZhou City