

SPECIFICATION

MED 5PX40AWG+4X40AWG TC

Customer Reference.
.....

Customer Signed by.
.....

SHS TECHNOLOGY CO.,LTD

苏尚虹鑫电子科技有限公司

Approved	Check	Drawing
Lester.Xu	Lester.Xu	Carter.Wang

(From:DE-2001-01 Rev.1)

1. Scope

This specification covers multi micro-coaxial cable for medical equipment.

2. Construction and Material

Item		Unit	Specified Value	
Core Number		-	5P	4C
Conductor	AWG Size	-	40	
	Material	-	Tinned copper alloy	
	Stranding	No./mm	7/0.03	
Insulation	Material	-	PFA	PFA
	Color	-	See Table.1	
	Thickness	mm	0.035	0.03
	Diameter	mm	0.16±0.02	0.15±0.02
Twisted	Pitch	mm	Max. 5.0	-
Cabling	Tape	-	PET Tape (See Fig.1)	
Spiral Shield	Material	-	Tinned copper	
	Strand	mm	0.05	
	Coverage	%	Nom.95	
Jacket	Material	-	FEP (Color: Black)	
	Thickness	mm	0.08	
	Diameter	mm	1.10±0.08	

3. Electrical Properties

Item	Unit	Specified Value
		40AWG
Conductor Resistance (@ 20°C)	Ω /km	Max. 5,000
Insulation resistance (@ 20°C)	MΩ -km	Min. 500
Dielectric Strength	-	To withstand A.C. 500V for 1min
Impedance (@ TDR)	ohm	100±10

4. Package

- 1). Unit length : According to cumtomer requirement.
- 2). Package: Coiled into spool and then packed into carton box

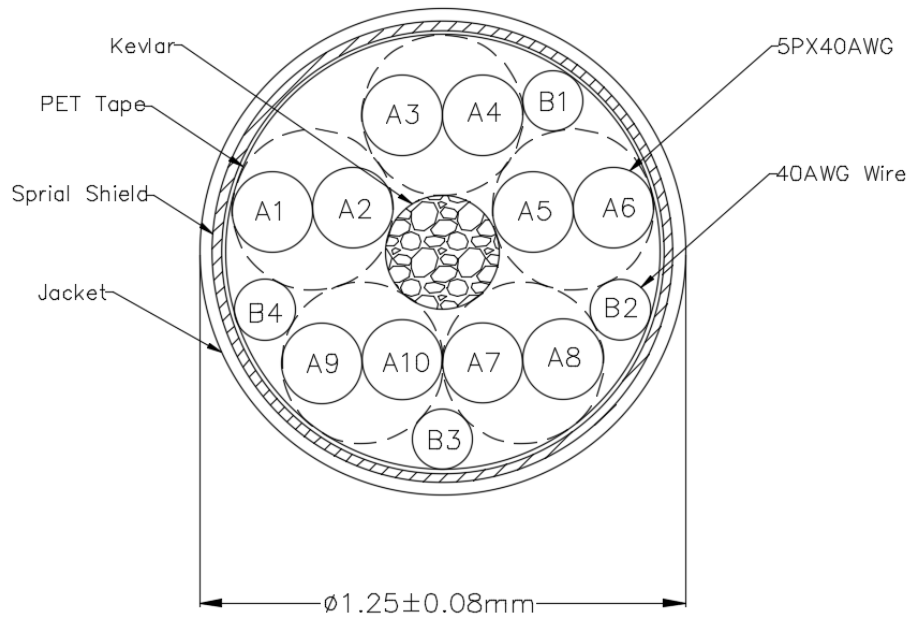

Fig.1 Cross section of cable.

Table.1 Color of each wire

Unit No.	Color	Unit No.	Color
A1	White	A8	Nature
A2	Black	A9	Gray
A3	Red	A10	Pink
A4	Green	B1	Orange
A5	Blue	B2	Purlpe
A6	Yellow	B3	Green
A7	Brown	B4	Red

REVISION RECORD

Rev. No	Issue date	Item	Drawing	Check	Approved
1	11/15/2021	Draft	Carter.W	Lester.X	Lester.X