

V1.0

2024.12

C-40D

Horizontal 2-axis Gimbal

User Manual

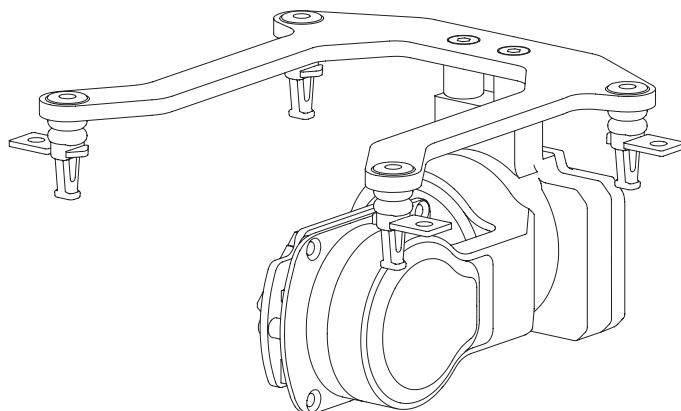

Using this Manual – Legend



Important



Tips



Explanation

Revision History

Date	Document Version
2024.12.31	V1.0

Caution

Always stay alert when using C-40D Horizontal 2-axis Gimbal and its accessories to control an unmanned aerial vehicle (UAV) or other carriers. Careless may result in serious harm to yourself and others.

1. Make sure that the external power supply for the gimbal is a lithium battery (2S~6S) with an input voltage between 7.4V~26.4V. Otherwise, the gimbal may work abnormally or be damaged.
2. DO NOT short circuit the power output and GND. Otherwise, the equipment may be damaged and may not work properly.
3. Follow the instructions in the user manual when installing the gimbal. Incorrect installation may cause the gimbal to not work properly.
4. Make sure that all connectors are secure and all parts are work properly.
5. Make sure you fully understand and abide by local laws and regulations before using this product.
6. This product is not intended for children.

Catalog

Introduction	1
Diagram	1
Installing the Payload	2
Controlling the C-40D	4
Headtracker Direct Control	4
Private Protocol Control	4
S.BUS / CRSF Control	4
PWM Control	4
MAVLink Control	4
Gimbal Modes	5
Gimbal Sensitivity	5
Carrier AHRS Fusion	5
Configuring, Calibrating & Firmware Upgrading	6
Connect the Gimbal	6
Parameter Configuration Basic Operation	7
Gimbal Presets	7
Channel Mapping	8
Mounting Type	8
Parameter Tuning	9
Calibrating & Firmware Upgrading	9
Appendix 1 MAVLink Configuration	10
ArduPilot	10
PX4	10

Introduction

The C-40D 2-axis Gimbal is compatible with a payload device no heavier than 40g. With a 2-axis mechanical stabilization structure and high-torque motors, the C-40D is able to provides an extreme stabilization effect against the vibration and high-speed air impact.

With the Headtracker, the C-40D provides an immersive high-quality first-person control experience.

Diagram

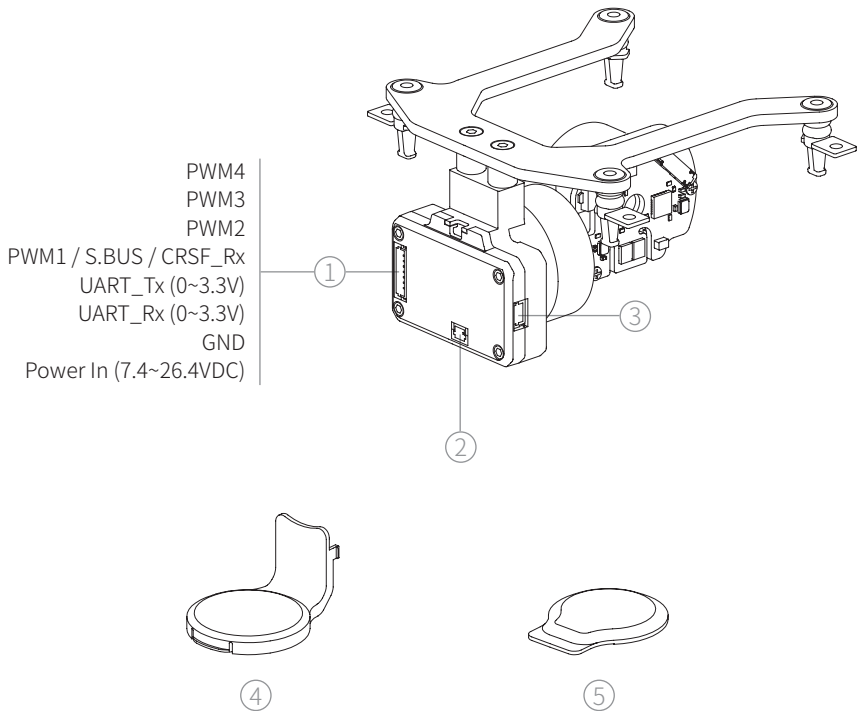

1. Power-communication Port (BM08B-SRSS-TB)

2. Reserved

3. Upgrade Port

4. Yaw Inner Lid

5. Yaw Outer Lid

Installing the Payload

1. Remove the four screws on the back of the gimbal, and separate the rear lid and interface PCBA from the gimbal.

! There are cables connecting between the gimbal and the interface PCBA. Do not separate the PCBA too far or may damage the gimbal.

2. Thread the payload cables through the hollow shaft of the roll motor, and install back the interface PCBA and the rear lid.

! Please protect the cables during installation.

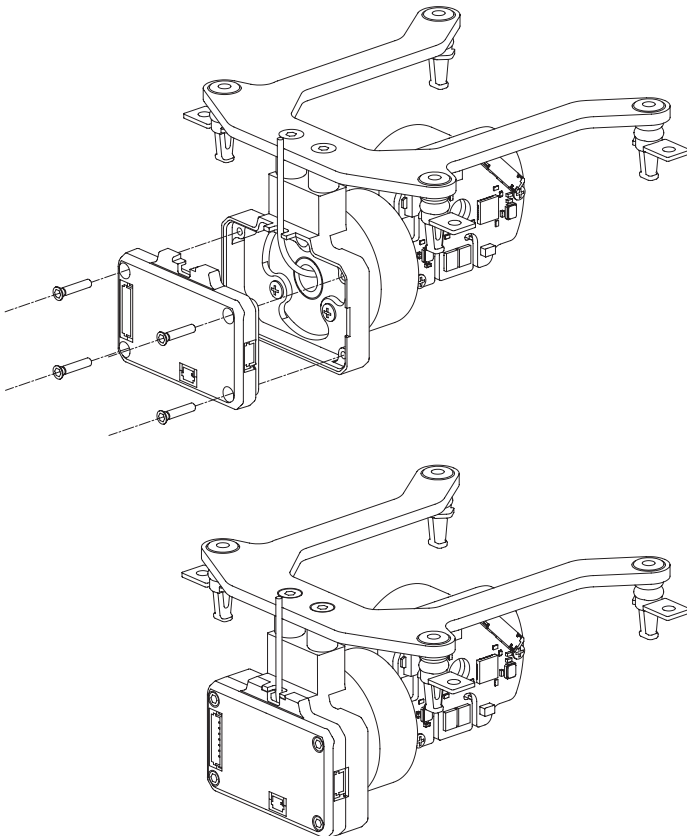

3. Route the payload cables through the pitch motor.

! The cables should have a certain margin length and should not be tight, otherwise it will lead the gimbal spinning unsmoothly or rebounding.

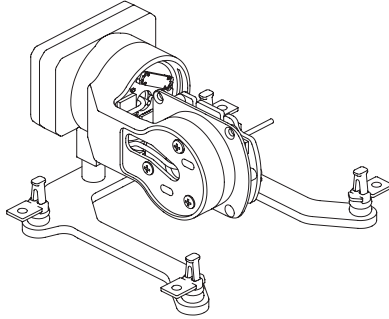

4. Install the lids as below.

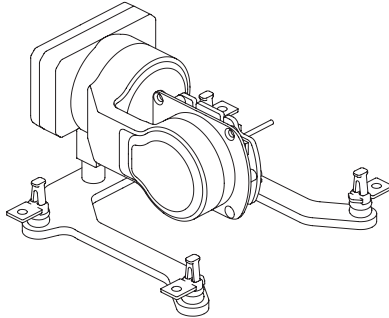

5. Mount the payload device onto the gimbal by four M1.6 countersunk head screws.

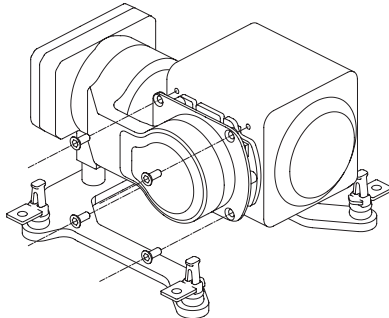

Controlling the C-40D

The C-40D supports Headtracker direct / private protocol control, S.BUS / CRSF control, PWM control and MAVLink control, with the priority of the four control methods above decreasing in order.

Headtracker Direct Control

Please refer to *Headtracker User Manual*.

Private Protocol Control

Please refer to *Gimbal Private Protocol*.

S.BUS / CRSF Control

Connect the PWM1 in power-communication port to the S.BUS or CRSF_Tx of the receiver, which needs 4 channels to control gimbal mode, gimbal sensitivity, roll and pitch respectively. Channel mapping can be done in the *GimbalConfig* software.

PWM Control

The PWM1~PWM3 are channels to control gimbal mode, gimbal sensitivity and gimbal pitch respectively.

MAVLink Control

Connect the UART_Rx and UART_Tx in power-communication port to the Tx and Rx in a certain serial port of the autopilot respectively, which needs 5 channels to control gimbal mode, gimbal sensitivity, roll, pitch and yaw respectively. Channel mapping can be done in the *GimbalConfig* software.

 Only ArduPilot firmware and PX4 firmware are supported currently. The MAVLink configuration are detailed in Appendix 1.

Gimbal Modes

There are three operating modes of the C-40D as below:

- FPV Mode (Mode 0)
Both two axes follow the movement of the carrier with eliminating slight shaking.
- Pitch-lock Mode (Mode 1)
The roll axis follows the movement of the carrier with eliminating slight shaking.
- Horizon Mode (Mode 2)
Both two axes keep current attitude.

Gimbal Sensitivity

The higher the sensitivity is, the quicker the response of the gimbal to follow the motion of the carrier, but the less it eliminates the carrier's wobble.



The gimbal sensitivity is valid only in FPV mode.

Carrier AHRS Fusion

When subjected to a large horizontal overload, the gimbal's attitude algorithm may exhibit certain deviations, resulting in an inclined attitude. To rectify this deviation, it is necessary to transmit valid carrier AHRS data (carrier GNSS positioning needs to be effective) to the gimbal via the MAVLink protocol. Carrier AHRS fusion is available in all control methods.

Configuring, Calibrating & Firmware Upgrading

Configure the gimbal and upgrade firmware of the gimbal with the *GimbalConfig* software.

-  Ensure the driver of the Config Module is installed on the computer before configuring, calibrating or upgrading.

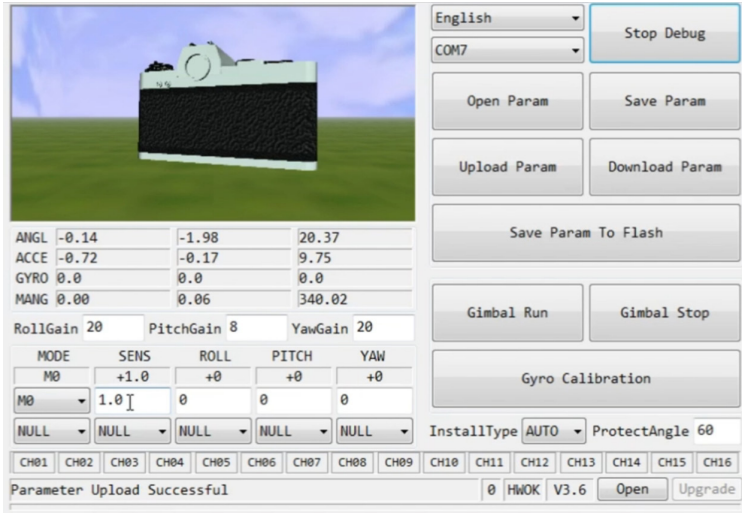

Connect the Gimbal

1. Connect the gimbal upgrading port and the computer with the J1.0 Config Module. Power up the gimbal.
2. Run the *GimbalConfig* software. Select the COM port corresponding to the Config Module. Click "Start Debug" and confirm the software and the gimbal being connected.

-  The Config Module is sold separately. For some brands of dual Type-C cables, there may be cases where the computer cannot recognize the Config Module. Please try replacing it with a Type-A to Type-C cable.

Parameter Configuration Basic Operation

After the gimbal is connected to the GimbalConfig software, the software will automatically download the parameter from the gimbal, or you can click “Download Param” to perform the download operation.

Click “Save Param” to save the current displayed parameter as a local file. Click “Open Param” to read a locally saved parameter file.

After selecting a new option in the drop-down box, the parameter will be automatically uploaded to the gimbal and take effect. After entering a new parameter in the parameter frame, press Enter key or click “Upload Param” to upload the parameter.

After the parameter is uploaded, click “Save Param To Flash” to finalize it into the gimbal.



The gimbal sensitivity only applies to the axes that follow the motion of the carrier.

Gimbal Presets

(Headtracker direct, S.BUS/CRSF & MAVLink control)

The gimbal works in accordance with the preset values when there is no signal input or no mapped channel assigned. After the signal input is restored, the gimbal exits the preset state. The gimbal presets are invalid in MAVLink control.

Preset gimbal mode: M0- FPV mode; M1- Pitch-lock mode; M2- Horizon mode.

Preset gimbal sensitivity: setting range -1.0~1.0, with a resolution of 0.1.

Preset roll, pitch and yaw angle: setting range $-180^{\circ} \sim 180^{\circ}$, with a resolution of 1° .



The actual effective preset angles are based on the maximum rotation range of the gimbal.



If you want to always use the preset values for some channels, map the corresponding channels to NULL.

Channel Mapping (Headtracker direct, S.BUS/CRSF & MAVLink control)

Select the channels corresponding to gimbal mode, gimbal sensitivity, roll, pitch and yaw respectively. For Headtracker direct control (through datalink or Air Unit), all channels should be mapped to CH01.

Mounting Type

The mounting type of the gimbal is AUTO by default, and the gimbal will automatically switch to DOWN/UP mode according to its attitude at power-on. The mounting type can also be manually set as DOWN or UP mode.

 For tail-sitter VTOL aircrafts, it should place the fuselage in a level flight attitude and power up, or manually set the mounting type of the gimbal.

 After the mounting type is set manually, make sure that the actual mounting type is consistent with the setting, otherwise the gimbal will enter the protection state.

Tilt Protection (Pitch-lock & Horizon mode)

When the tilt of the mounting plane of the gimbal exceeds the protect angle, the gimbal will enter the protection state, at this time the gimbal will be neutralized and uncontrollable. When the tilt of the mounting plane is smaller than the protect angle, the gimbal will automatically exit the protection state. Tilt protection is effective in Pitch-lock mode and Horizon mode, not in FPV mode.

The protection angle can be modified according to the actual use. The setting range is $0^{\circ} \sim 90^{\circ}$ with a resolution of 1° . $\leq 15^{\circ}$ means disabling the tilt protection.

 After disabling the tilt protection, the gimbal may work abnormally when the attitude angle of the carrier is large.

Parameter Tuning

For cameras with larger moment of inertia, mounting them on the gimbal may result in gimbal shaking. In such cases, increasing the gain value can enhance stabilization effects.

 It is strongly recommended to use the default gain parameters if unnecessary.

Calibrating & Firmware Upgrading

 If the attitude of the gimbal tilts or drifting slowing when no control signal input, it is necessary to calibrate the gimbal.

1. To calibrate the gimbal. Keep the gimbal static. Click "Gyro Calibration" and wait for the calibration to complete.
2. To upgrade the firmware. Click "Open Firmware". Select the firmware file. Click "Start Upgrade" and wait for the upgrade to complete.

Appendix 1 MAVLink Configuration

ArduPilot

SERIAL1	
SERIAL1_BAUD	115
SERIAL1_OPTIONS	1024
SERIAL1_PROTOCOL	2
SR1	
SR1_ADSB	0 Hz
SR1_EXIT_STAT	0 Hz
SR1_EXTRA1	0 Hz
SR1_EXTRA2	0 Hz
SR1_EXTRA3	0 Hz
SR1_PARAMS	0 Hz
SR1_POSITION	0 Hz
SR1_RAW_CTRL	0 Hz
SR1_RAW_SENS	0 Hz
SR1_RC_CHAN	0 Hz



Serial port number can be changed according to the actual situation.

PX4

MAVLink	
MAV_1_CONFIG	TELEM2
MAV_1_MODE	Custom / Gimbal
MAV_1_RATE	115200 B/s
Serial	
SER_TEL2_BAUD	115200 8N1



The MAV_1_MODE is recommended as Custom.