

# **BRECO** *flex* CO., L.L.C.

High Precision Drive Components

The World Leader In Polyurethane Timing Belts

## **TIMING BELT BACKINGS**

Materials and Characteristics



# SUPERIOR TIMING BELT BACKINGS

## Strength *and* Flexibility



BRECOflex CO., L.L.C., the pioneer and world leader in the polyurethane timing belt industry, offers high precision timing belts with a wide variety of backings for use in conveying, positioning, material handling, and related applications. We manufacture all backings to provide excellent wear resistance and resilience.

Some backings are multi-functional while others are highly specialized. The appropriate selection of the backing material depends on the individual application. Our engineers are available to specify timing belts with the backing that most effectively meets your requirements.

BRECOflex belts with backings, available in various thicknesses, offer different ranges of hardness, density, abrasion resistance, and coefficients of friction to suit your application. We utilize a heated chemical bonding process to adhere the backing to the belt. Superior know-how and state-of-the-art processes ensure a strong bond.

To meet the needs of your specific application, BRECOflex can mechanically rework the tooth side and/or the transport side of the belt. See pages 18-19 for more details.

There are many characteristics to consider when choosing a backing for your application. Some special considerations are shown below. For additional information, refer to the chart next to each backing material on the following pages.

### Friction

The backing you choose depends on the transport item properties and the required grip. Choose high friction for a good carrying effect, low friction for accumulating conveyors. Note that when belt load increases so does friction and therefore heat. Choose a slider bed plate material that will have a minimum friction value against the belt. Friction value increases as temperatures rise and reduces at temperatures below freezing.

### Drives With Back-Bending

Timing belts with backings are generally suitable for drives with back-bending. Very soft backings such as Sylomer should be set up with reduced pretensioning. Backings made of natural rubber such as Linatex, can be used for back-bending (back pulleys) but only to a limited extent. Please consult our engineering department for more detailed information.

### Pulley Diameter

At low ambient temperatures, the flexibility of the backing reduces. You should therefore select larger pulley diameters than you would at normal temperatures. The flexibility of the timing belt also reduces at low temperatures.

The minimum diameters referenced for the backings in this catalog serve as a guideline. They apply at an ambient temperature of 20°C (68°F) and speed of 1 m/s, and assuming a low load burden. If the exact usage details are known, it is possible to reduce the diameters. Likewise the minimum specified pulley diameters apply for homogeneously applied backings of even thickness. Machined backings such as those with cuts or grooves cause notch effects and require much higher minimum diameters. In these cases, our applications engineers will be happy to assist you.

# SUPERIOR TIMING BELT BACKINGS

## Belt Construction

### Timing Belt Properties

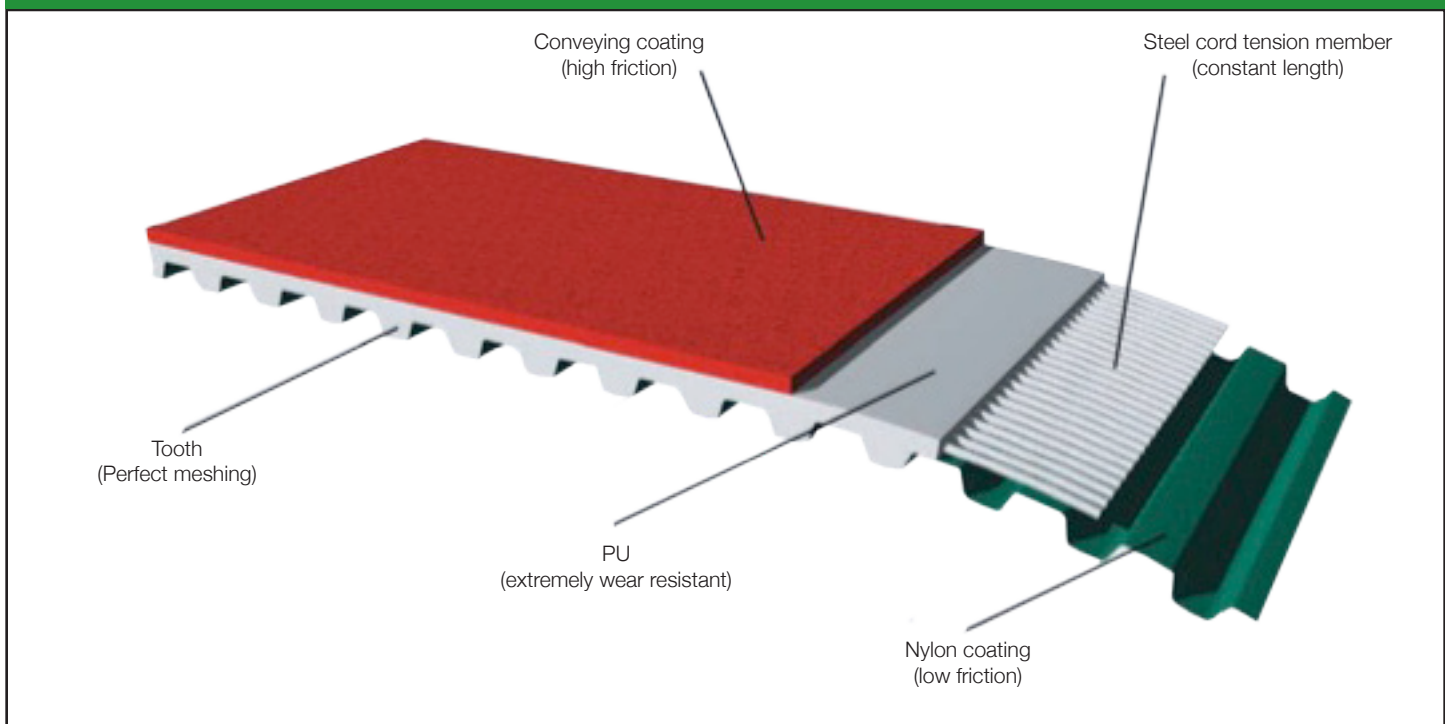

### Temperature Effect

When transporting hot goods above approx. 80°C (176°F) the duration of contact should be as short as possible to avoid heating the belt's substructure to over 80°C (176°F). Limit exposure to heat to short distances and times then provide sufficient cooling for the remaining revolution period. At temperatures approximately 60°C (140°) and up, the tooth shear strength reduces slightly. If the teeth are subjected to major stress you should increase your safety factor.

### Resistance

Material resistance needs to be evaluated for every application. The material resistance depends, among other factors, on the pH value, the concentration, the temperature and the influencing time of the medium. Simple oils generally have no damaging effect on the belt. Additives in the oil and temperatures over approx. 40°C (104°F) can reduce the longevity.

### Larger Belts and Thick Backings

Please consult engineering support for backings over 75 mm wide and 2 mm thick because of the different processing properties that vary by material.

As a single source supplier, BRECOflex CO., L.L.C. can provide all of the drive components and accessories for our timing belts to insure the highest accuracy, perfect meshing and longest service life.

SYNCHRONIZING PULLEY DIAMETER  
DEPENDENT ON TEMPERATURE

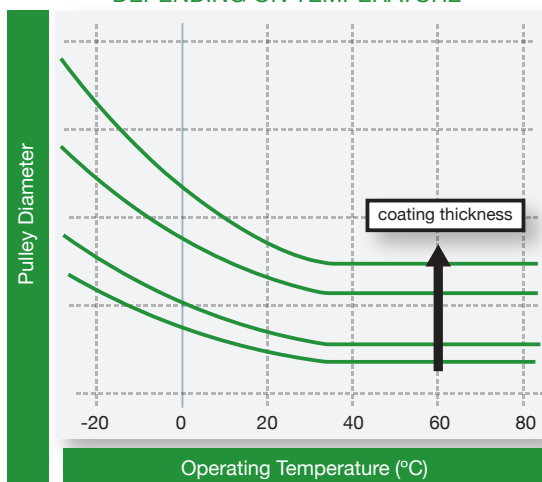

# TIMING BELT BACKINGS

## For General Conveying

### Linatex

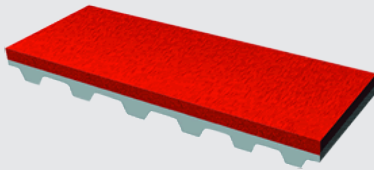

#### Properties

Standard Thickness(mm)	2	3	4	5	6	8	10
Min. pulley diameter(mm)	60	70	80	90	100	110	120
Material / Hardness	95% natural rubber/ approx. 38 Shore A						
Tolerances	tolerance for total thickness (timing belt +coating) -1/+1.8mm (ground ±0.2 mm possible)						
Temperature resistance	-40°C to +70°C (-40°F to 158°F)						
Chemical resistance	oil-proof to a limited extent, resistant to wet abrasion, water resistant, avoid exposure to direct sunlight						
Machinability	contours can be ground and milled to some extent						
Note	from 3mm coating thickness please ask for advice						

### Linatrilite

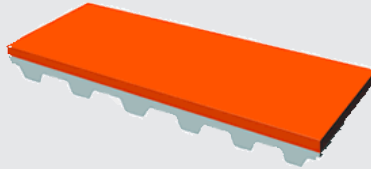

#### Properties

Standard Thickness(mm)	3	5	6
Min. pulley diameter(mm)	50	60	80
Material / Hardness	Nitrile-based vulcanized material, approx. 55 Shore A		
Tolerances	tolerance for total thickness (timing belt + coating ± 0.4mm) (ground ±0.1mm possible)		
Temperature resistance	-20°C to +110°C (-4°F to 230°F)		
Chemical resistance	resistant to oils, greases and other chemicals; water resistant		
Machinability	contours can be ground and milled and surface ground		

### Supergrip

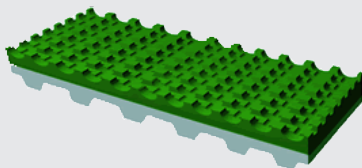

#### Properties

Standard Thickness(mm)	4
Min. pulley diameter(mm)	60
Material / Hardness	PVC, approx. 40 Shore A
Tolerances	tolerance for total thickness (timing belt + coating) ±0.5mm
Temperature resistance	-15°C to +90°C (5°F to 194°F)
Chemical resistance	limited resistance to solvents, oils and greases; resistant to acids and alkalis

Available Colors:   

# TIMING BELT BACKINGS

## For General Conveying

### T-Cover/PU 385

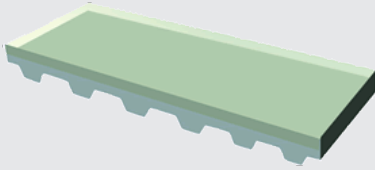



#### Properties

Standard Thickness(mm)	3	4	5	6
Min. pulley diameter(mm)	80	120	150	180
Material / Hardness	polyurethane/approx. 85 Shore A			
Tolerances	tolerance for total thickness (timing belt + coating) $\pm 0.4$ mm (ground $\pm 0.1$ mm possible)			
Temperature resistance	-20°C to +80°C (-4°F to 176°F)			
Chemical resistance	resistant to simple oils and grease, petrol, ozone			
Machinability	contours can be ground and milled and surface ground			

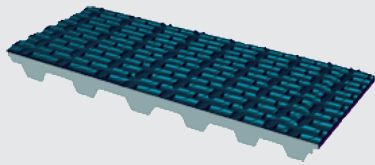
### Minigrip



Available Colors:  

#### Properties

Standard Thickness(mm)	1.5
Min. pulley diameter(mm)	30
Material / Hardness	PVC, approx. 50 Shore A
Tolerances	tolerance for total thickness (timing belt + coating) $\pm 0.5$ mm
Temperature resistance	-15°C to +90°C (-40°F to 194°F)
Chemical resistance	resistance to solvents, oils and greases; resistant to acids and alkalis

### PVC Blue

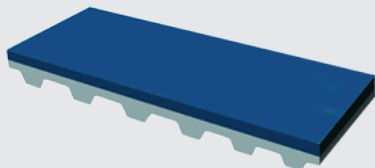

#### Properties

Standard Thickness(mm)	1	(2 / 3 / 4 / 5 / 6 mm upon request)
Min. pulley diameter(mm)	30	
Material / Hardness	PVC, approx. 65 Shore A	
Tolerances	tolerance for total thickness (timing belt + coating) $\pm 0.5$ mm	
Temperature resistance	-15°C to +90°C (-40°F to 194°F)	
Chemical resistance	limited resistance to solvents, oils and greases; resistant to acids and alkalis	
Other areas of use	pharmaceutical industry	

# TIMING BELT BACKINGS

## For General Conveying

### PU Yellow

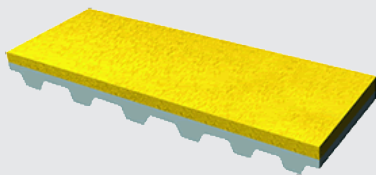

#### Properties

Standard Thickness(mm)	2	3	4	5	6
Min. pulley diameter(mm)	70		90	110	
Material / Hardness	polyurethane/approx. 55 Shore A				
Tolerances	tolerance for total thickness (timing belt + coating $\pm 0.4$ mm) (ground $\pm 0.1$ mm possible)				
Temperature resistance	-30°C to +70°C (-22°F to 158°F)				
Chemical resistance	resistant to simple oils and grease, petrol, ozone				
Machinability	contours can be ground and milled and surface ground				
Other areas of use	paper, cardboard, glass conveying.				

### D15 Polyurethane

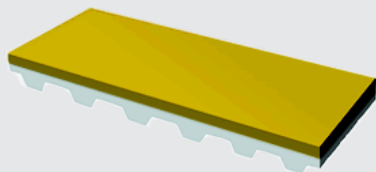

Available Colors:

#### Properties

Standard Thickness(mm)	2	3	4	5	6
Min. pulley diameter(mm)	60	80		100	
Material / Hardness	polyurethane/approx. 70 Shore A				
Tolerances	tolerance for total thickness (timing belt + coating) $\pm 0.6$ mm (ground $\pm 0.1$ mm possible)				
Temperature resistance	-20°C to +80°C (-4°F to 176°F)				
Chemical resistance	resistant to simple oils and greases, good resistance to ozone, UV radiation				
Machinability	contours can be ground and milled and surface ground				

### NBR 65

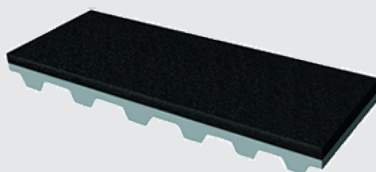

#### Properties

Standard Thickness(mm)	1.5		3		
Min. pulley diameter(mm)	60		80		
Material / Hardness	nitrile rubber, approx. 60-70 Shore A				
Tolerances	tolerance for total thickness (timing belt + coating) $\pm 0.6$ mm (ground $\pm 0.2$ mm possible)				
Temperature resistance	-35°C to +70°C (-31°F to 158°F)				
Chemical resistance	resistant to oils and to some extent acids and alkalis				
Machinability	contours can be ground and milled to some extent and surface ground				

# TIMING BELT BACKINGS

## For General Conveying

### TR2

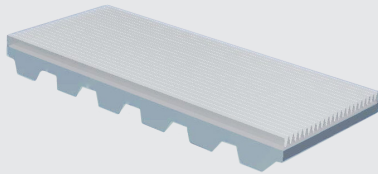

#### Properties

Standard Thickness(mm)	2.5 / Groove depth: 1.4
Min. pulley diameter(mm)	80
Material / Hardness	polyurethane, approx. 85 Shore A
Tolerances	tolerance for total thickness (timing belt + coating) $\pm 0.5\text{mm}$
Temperature resistance	-20°C to +80°C (-4°F to 176°F)
Chemical resistance	resistant to simple oils, grease, petrol, and ozone

### WM 385

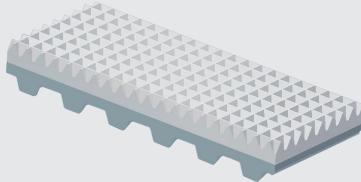

#### Properties

Standard Thickness(mm)	4
Min. pulley diameter(mm)	120
Material / Hardness	polyurethane, approx. 85 Shore A
Tolerances	tolerance for total thickness (timing belt + coating) $\pm 0.5\text{mm}$
Temperature resistance	-20°C to +80°C (-4°F to 176°F)
Chemical resistance	resistant to simple oils, grease, petrol, and ozone

### NP 385

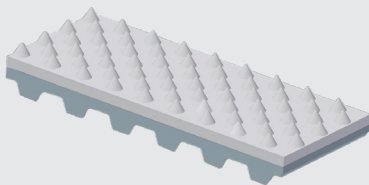

#### Properties

Standard Thickness(mm)	4
Min. pulley diameter(mm)	120
Material / Hardness	polyurethane, approx. 85 Shore A
Tolerances	tolerance for total thickness (timing belt + coating) $\pm 0.4\text{mm}$
Temperature resistance	-20°C to +80°C (-4°F to 176°F)
Chemical resistance	resistant to simple oils, grease, petrol, and ozone

# TIMING BELT BACKINGS

## For General Conveying

### RP 430

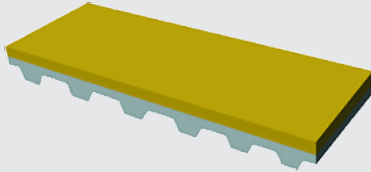

#### Properties

Standard Thickness(mm)	2	3	4	5	6
Min. pulley diameter(mm)	40		50	70	
Material / Hardness	natural rubber, approx. 39 Shore A				
Tolerances	tolerance for total thickness (timing belt + coating $\pm 0.4$ mm) (ground $\pm 0.1$ mm possible)				
Temperature resistance	-35°C to +80°C (-31°F to 176°F)				
Chemical resistance	resistant to simple oils and grease				
Machinability	contours can be ground and milled and surface ground				

### Celloflex

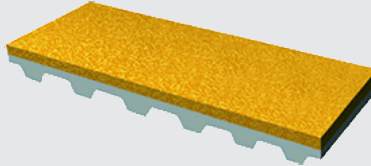

#### Properties

Standard Thickness(mm)	2	3	4	5	6	8	10
Min. pulley diameter(mm)	40	60		80		100	120
Material / Hardness	microcellular elastomer polyurethane/ approx. 350 kg/m <sup>3</sup>						
Tolerances	tolerance for total thickness (timing belt + coating) $\pm 0.7$ mm						
Temperature resistance	-30°C to +80°C (-22°F to 158°F)						
Chemical resistance	resistant to simple oils and grease, ozone						
Machinability	contours can be ground and milled and surface ground						

### Silicone Endless

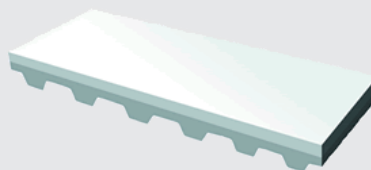

#### Properties

Standard Thickness(mm)	2	3	4	5	6	8	10
Min. pulley diameter(mm)	60	70	80	90	100	110	120
Material / Hardness	Silicone, approx. 35 Shore A						
Tolerances	tolerance for total thickness (timing belt + coating) $\pm 0.1$ mm						
Temperature resistance	-20°C to +100°C (4°F to 212°F)						
Chemical resistance	Good resistance to ink, dirt and adhesives						
Areas of use	Printing, high temperature resistance, high friction, ground or sealed surface, FDA compliant						

Available Colors:

# TIMING BELT BACKINGS

## For General Conveying

### Porol

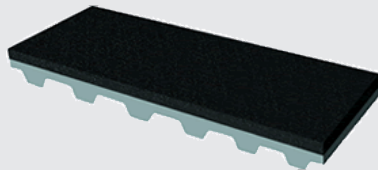

### Properties

Standard Thickness(mm)	3	5	10
Min. pulley diameter(mm)	40	60	80
Material / Hardness	closed-cell cellular rubber, 160-200 kg/m <sup>3</sup>		
Tolerances	tolerance for total thickness (timing belt + coating) $\pm 0.7$ mm		
Temperature resistance	-40°C to +75°C (-40°F to 167°F)		
Chemical resistance	resistant to water, seawater, methanol, acetone, detergent, acids and alkalis		

### Sylomer

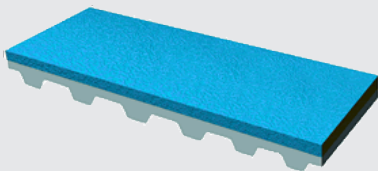

### Properties

Standard Thickness(mm)	6	12	(Other thickness upon request)
Min. pulley diameter(mm)	60	80	
Material / Hardness	mixed cell polyurethane, 220 kg/m <sup>3</sup>		
Tolerances	tolerance for total thickness (timing belt + coating) $\pm 0.7$ mm (ground $\pm 0.3$ mm possible)		
Temperature resistance	-30°C to + 70°C (-22°F to 158°F)		
Chemical resistance	resistant to simple oils and grease		
Machinability	contours can be ground and milled to some extent and surface ground		
Note	Sylomer colors offer different characteristics, contact applications engineering for more details		

Available Colors: 

### Correx Beige

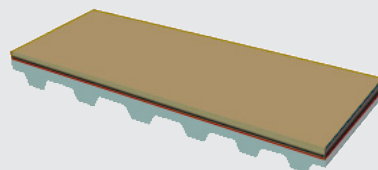

### Properties

Standard Thickness(mm)	6	10
Min. pulley diameter(mm)	80	120
Material / Hardness	para rubber, approx. 36 Shore A	
Tolerances	tolerance for total thickness (timing belt + coating) $\pm 0.7$ mm (ground $\pm 0.2$ mm possible)	
Temperature resistance	up to approx. +70°C (158°F)	
Chemical resistance	resistant to simple oils and grease, ozone	
Machinability	contours can be ground and milled to some extent and surface ground	

# TIMING BELT BACKINGS

## For Food Processing

### Linaplus FDA

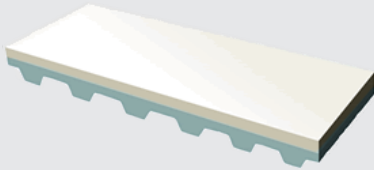

#### Properties

Standard Thickness(mm)	3	5	6
Min. pulley diameter(mm)	70	90	100
Material / Hardness	vulcanized natural rubber, approx. 38 Shore A		
Tolerances	tolerance for total thickness (timing belt + coating) -1/+1.8mm (ground $\pm 0.2$ mm possible)		
Temperature resistance	-40°C to +70°C (-40°F to 158°F)		
Chemical resistance	resistant to chemicals; material does not leave pressure marks		
Machinability	contours can be ground and milled and surface ground		
Note	FDA approval in conformity with the criteria of the FDA Code of Federal Regulations, section 177.1680, the European Regulation (EC) 1935-2004, Regulation (EU) no, 10-2011 and European Commission Directives 90/128/EEC and 96/11/EC		

### PVC White FDA

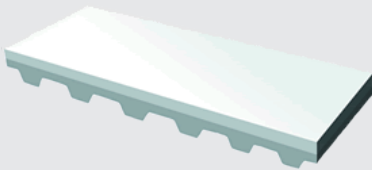

#### Properties

Standard Thickness(mm)	2	(2 / 3 / 4 / 5 / 6 mm upon request)
Min. pulley diameter(mm)	60	
Material / Hardness	PVC, approx. 48 Shore A	
Tolerances	tolerance for total thickness (timing belt + coating) $\pm 0.5$ mm	
Temperature resistance	-10°C to +110°C (14°F to 230°F)	
Chemical resistance	resistant to oils, greases, acids and alkalis	
Note	FDA approval in conformity with the criteria of the FDA Code of Federal Regulations, section 177.1680, the European Regulation (EC) 1935-2004, Regulation (EU) no, 10-2011 and European Commission Directives 90/128/EEC and 96/11/EC	

### PVC White Herringbone FDA

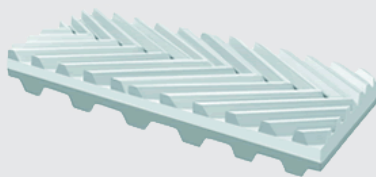

#### Properties

Standard Thickness(mm)	3
Min. pulley diameter(mm)	60
Material / Hardness	PVC, approx. 65 Shore A
Tolerances	tolerance for total thickness (timing belt + coating) $\pm 0.5$ mm
Temperature resistance	-10°C to + 110°C (14°F to 230°F)
Chemical resistance	resistant to oils, greases, acids and alkalis
Note	FDA approval in conformity with the criteria of the FDA Code of Federal Regulations, section 177.1680, the European Regulation (EC) 1935-2004, Regulation (EU) no, 10-2011 and European Commission Directives 90/128/EEC and 96/11/EC

# TIMING BELT BACKINGS

## For Food Processing

### Supergrip White FDA

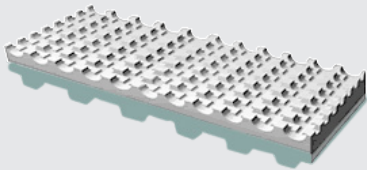

#### Properties

Standard Thickness(mm)	3
Min. pulley diameter(mm)	60
Material / Hardness	PVC, approx. 38 Shore A
Tolerances	tolerance for total thickness (timing belt + coating) $\pm 0.5$ mm
Temperature resistance	-40°C to +70°C (-40°F to 158°F)
Chemical resistance	resistant to oils, greases, acids and alkalis
Note	FDA approval in conformity with the criteria of the FDA Code of Federal Regulations, section 177.1680, the European Regulation (EC) 1935-2004, Regulation (EU) no, 10-2011 and European Commission Directives 90/128/EEC and 96/11/EC

### White Nub FDA

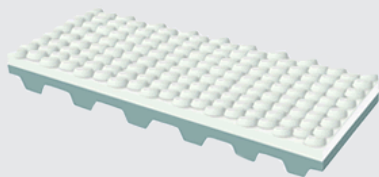

#### Properties

Standard Thickness(mm)	1.6
Min. pulley diameter(mm)	60
Material / Hardness	PVC, approx. 55 Shore A
Tolerances	tolerance for total thickness (timing belt+coating) $\pm 0.5$ mm
Temperature resistance	-20°C to + 80°C (-4°F to 176°F)
Chemical resistance	resistant to simple oils and fats
Note	FDA approval in conformity with the criteria of the FDA Code of Federal Regulations, section 177.1680, the European Regulation (EC) 1935-2004, Regulation (EU) no, 10-2011 and European Commission Directives 90/128/EEC and 96/11/EC

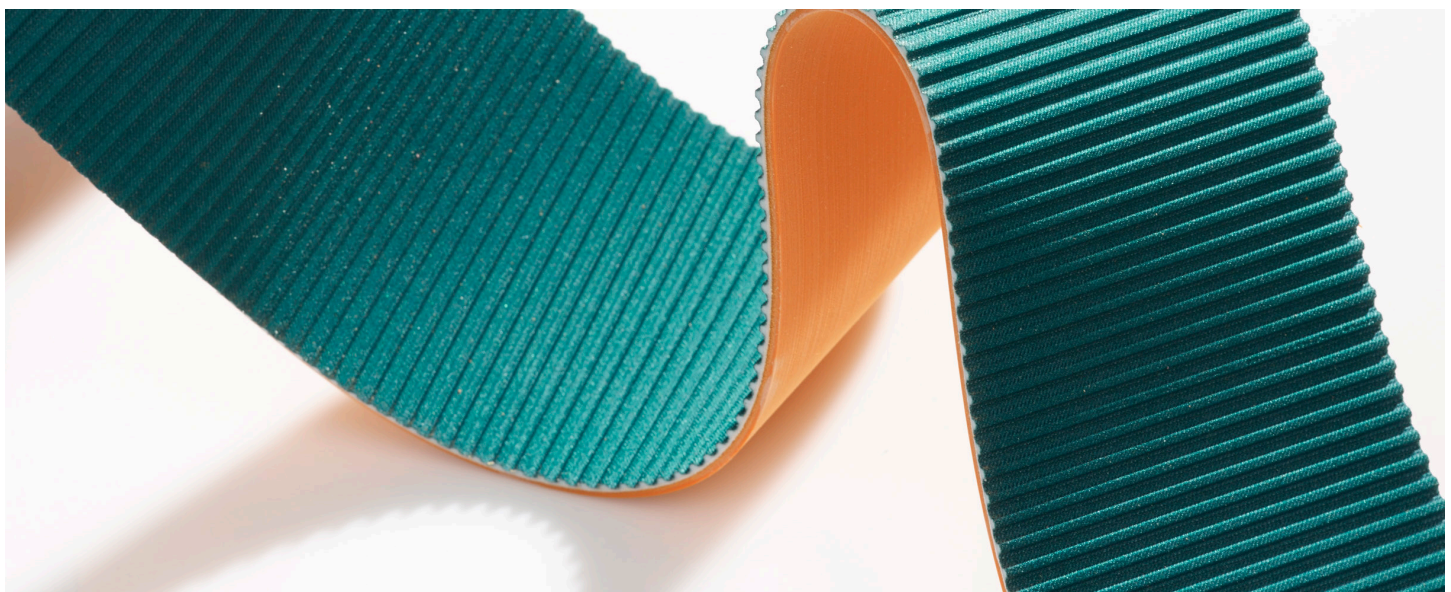

# TIMING BELT BACKINGS

## For High Temperature

### TT 60

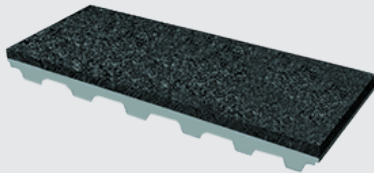

#### Properties

Standard Thickness(mm)	2
Min. pulley diameter(mm)	120
Material / Hardness	polyester fleece
Tolerances	tolerance for total thickness (timing belt + coating) $\pm 0.4$ mm (ground $\pm 0.1$ mm possible)
Temperature resistance	-20°C to +110°C (14°F to 230°F)
Chemical resistance	resistant to oils and greases; electrostatic properties
Areas of use	glass industry, as a conveyor belt in a warm area

### EPDM Endless

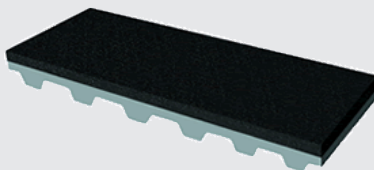

#### Properties

Standard Thickness(mm)	2	4	6
Min. pulley diameter(mm)	60	80	120
Material / Hardness	Rubber, approx. 65 Shore A		
Tolerances	tolerance for total thickness (timing belt + coating) $\pm 0.1$ mm		
Temperature resistance	-40°C to +120°C (40°F to 248°F)		
Chemical resistance	Very good resistance to acids and alkalis, weathering resistant		

### Chromeleder

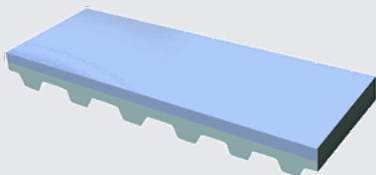

#### Properties

Standard Thickness(mm)	2	3
Min. pulley diameter(mm)	100	120
Material / Hardness	leather tanned with chromium salts	
Tolerances	tolerance for total thickness (timing belt + coating) $\pm 0.7$ mm	
Temperature resistance	-10°C to +120°C (14°F to 248°F)	
Chemical resistance	resistant to oils and greases; weather resistant	
Potential applications	transportation of oil and grease soaked parts, transportation of sheet metal and pipes	

# TIMING BELT BACKINGS

## For High Temperature

### PTFE

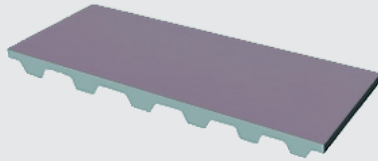

### Properties

Standard Thickness(mm)	0.25
Min. pulley diameter(mm)	40
Material / Hardness	Polytetrafluoroethylene, approx. 85 Shore A
Tolerances	tolerance for total thickness (timing belt+coating) $\pm 0.2$ mm
Temperature resistance	-200°C to +200°C (-328°F to 392°F)
Chemical resistance	good resistance to many acids, bases and solvents

### Viton

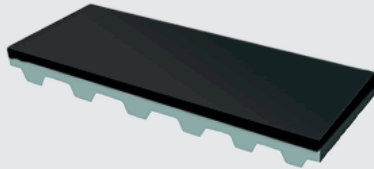

### Properties

Standard Thickness(mm)	2	4
Min. pulley diameter(mm)	80	100
Material / Hardness	synthetic fluoroelastomer, approx. 70-80 Shore A	
Tolerances	tolerance for total thickness (timing belt + coating) $\pm 0.6$ mm (ground $\pm 0.2$ mm possible)	
Temperature resistance	-10°C / 190°C (14°F / 374°F) (up to 275°C for short periods)	
Chemical resistance	very good resistance to oils, greases, hydrocarbons, acids; impermeable to gas and water vapor	
Machinability	contours can be ground and milled and surface ground	
Potential Applications	transportation of sensitive parts, cardboard packaging, transportation of glass and metal parts	



# TIMING BELT BACKINGS

## For Reduced Friction

### PAR

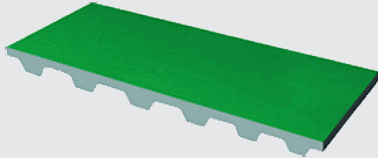

### Properties

Standard Thickness(mm)	0.5	0.8
Min. pulley diameter(mm)	15	25
Material / Hardness	polyamid	
Tolerances	± 0.2 mm	
Temperature resistance	-20°C to +50°C (4°F to 122°F)	
Chemical resistance	resistant to simple oils and grease	

### PAZ

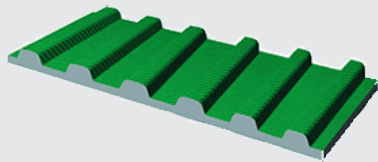

### Properties

Standard Thickness(mm)	0.5	0.8
Min. pulley diameter(mm)	15	25
Material / Hardness	polyamid	
Tolerances	± 0.2 mm	
Temperature resistance	-20°C to +50°C (4°F to 122°F)	
Chemical resistance	resistant to simple oils and grease	
Note	Material can only be applied during extrusion process	

### PAZ-PAR

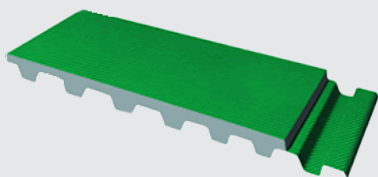

### Properties

Standard Thickness(mm)	0.5	0.8
Min. pulley diameter(mm)	15	25
Material / Hardness	polyamid	
Tolerances	± 0.2 mm	
Temperature resistance	-20°C to +50°C (4°F to 122°F)	
Chemical resistance	resistant to simple oils and grease	

# TIMING BELT BACKINGS

## For Reduced Friction

### PAZ-PAR, Anti-Static

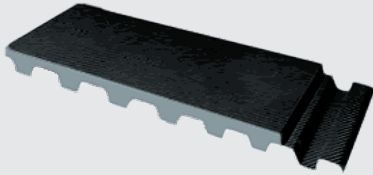

### Properties

Standard Thickness(mm)	0.6
Min. pulley diameter(mm)	20
Material / Hardness	approx. 0.5mm PU 385, top layer 0.1mm anti-static fabric
Tolerances	tolerance for total thickness (timing belt + coating) $\pm 0.4$ mm
Conductance	$10^5$ ohm when new
Potential applications	accumulation conveyors for electrical components

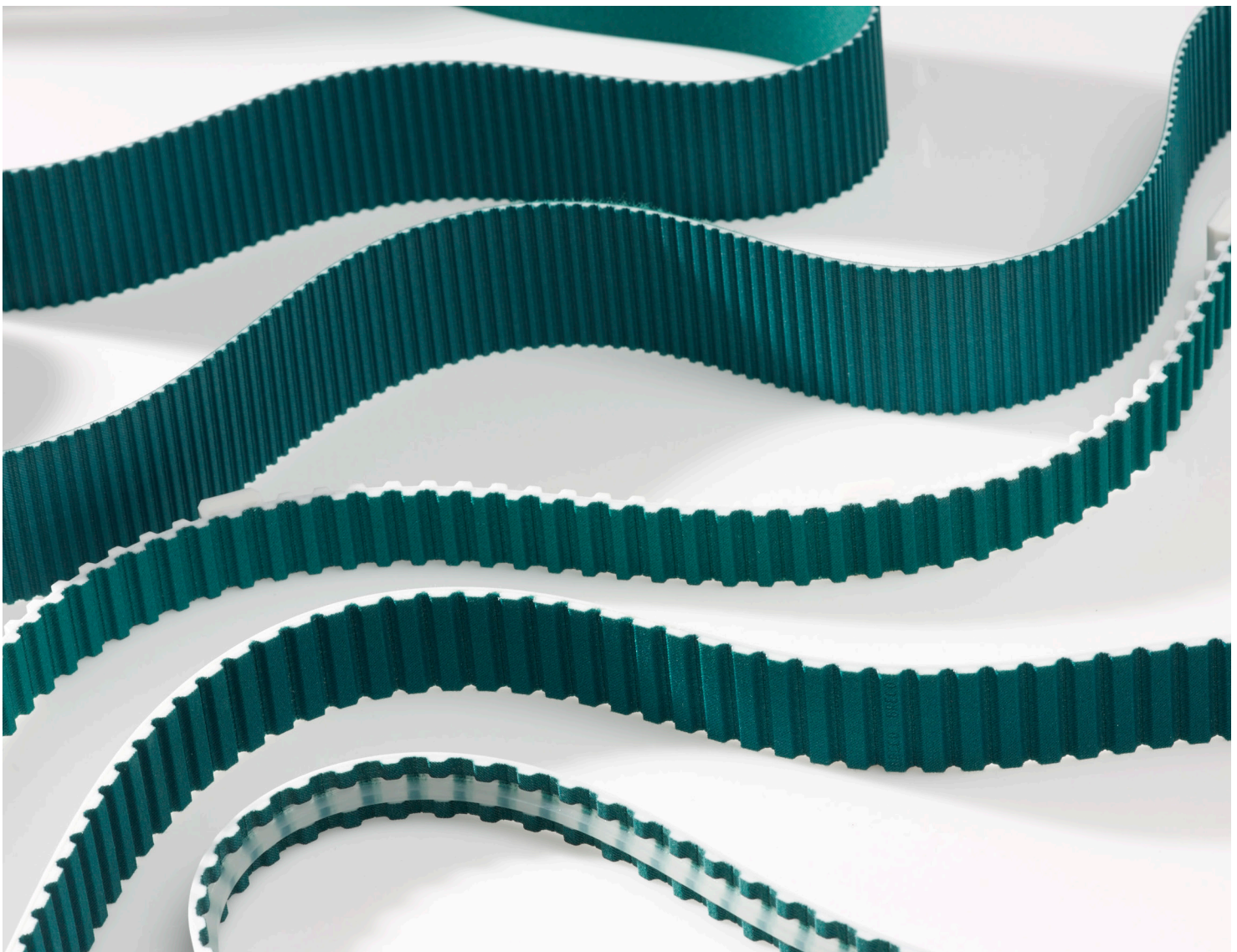

# TIMING BELT BACKINGS

## Machined Backings

### Custom Machined Backings

Certain backings allow for special machining and processing to provide for synchronous conveying and positioning of goods. Pockets, contours, slots, holes, etc. can be precisely machined for each requirement. Please contact Applications Engineering for assistance.

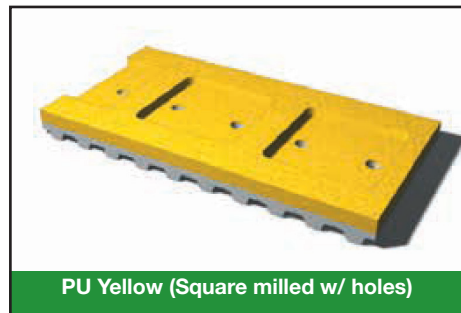
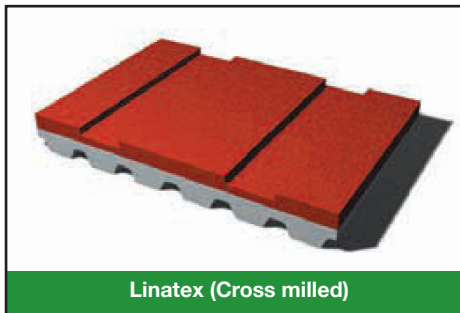

### Reduced Stress Concentration

Covered timing belts have reduced bending ability. Therefore, larger diameter pulleys and idlers must be used in order to reduce stress concentration. The bending flexibility can be increased by up to 30% by properly placing stress reliefs in the backing material.

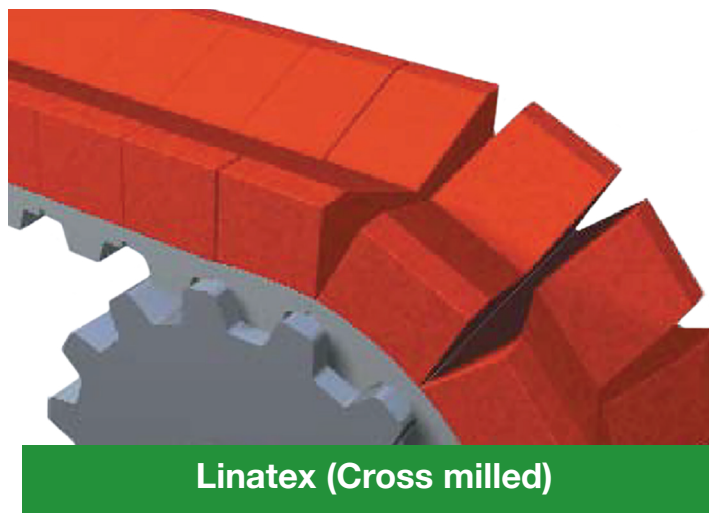

### Notes to the Designer:

- Additives in oils and temperatures above 40°C (140°F) will reduce belt life
- The coefficient of friction changes with temperature
- Low ambient temperatures reduce flexibility of the backing material. Pulley and idler diameters must be increased accordingly.
- Covered belt applications may require increased pulley and idler diameters in standard and back bending operations.



# TIMING BELT BACKINGS

## Backing Chart

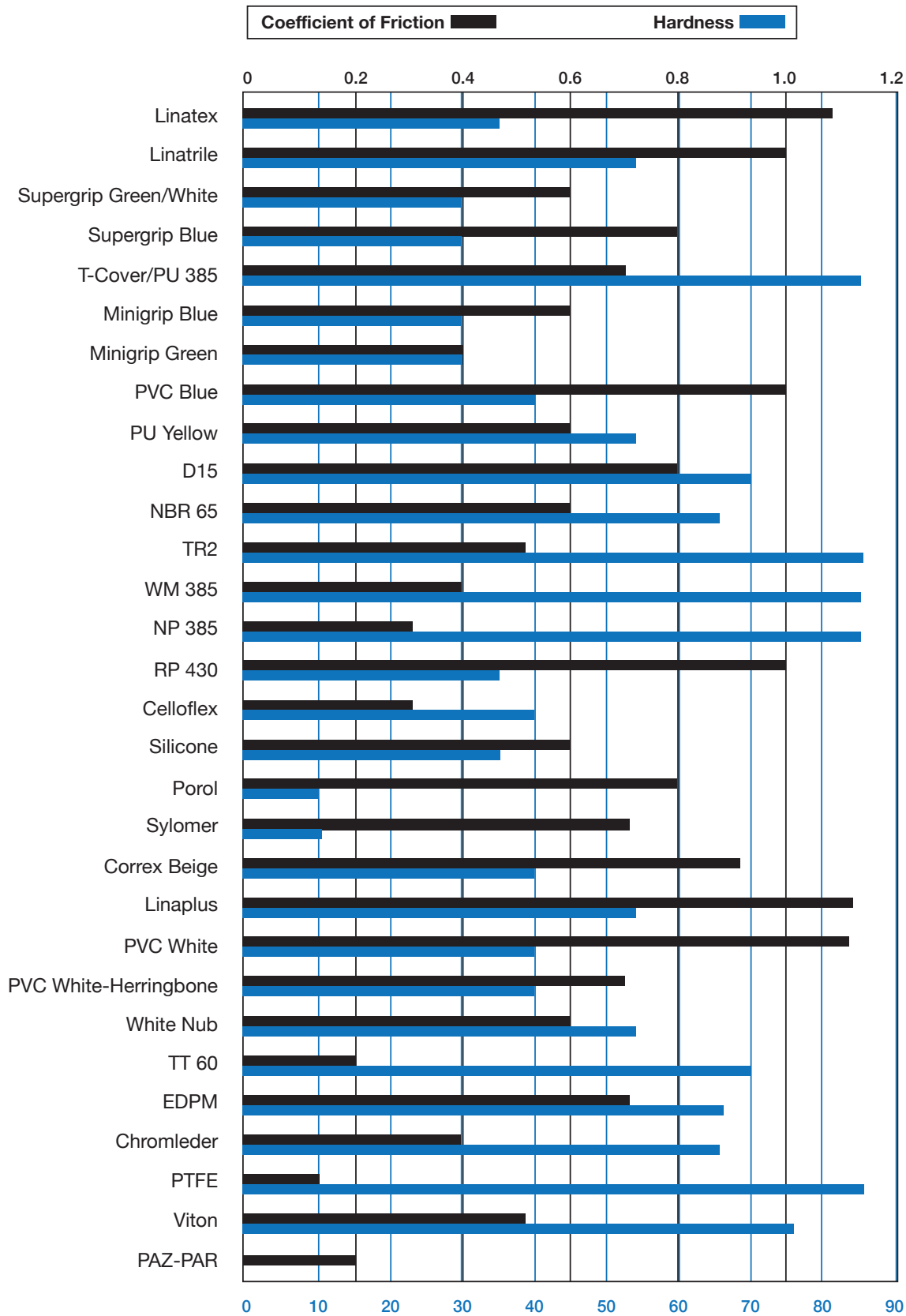

**NOTE:** Coefficient of friction will vary depending on the objects being conveyed.

# TIMING BELT BACKINGS

## Machined Timing Belts

### Custom Machined Timing Belts

BRECOflex CO., L.L.C. can mechanically process timing belts for special functional characteristics. Timing belts with thick backs offer a broad range of possibilities for design engineers especially for mechanical processing. Please note that timing belts with thicker backs are less flexible and require toothed pulleys with larger diameters. Better flexibility is achieved through transverse grooves or slits.

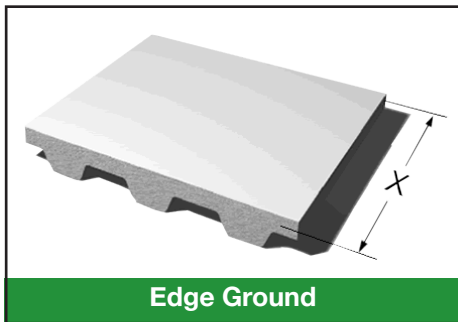

- Improved belt width tolerance
- Less lateral movement
- Used to more accurately position mechanical modifications (i.e. profiles, perforations, etc.)

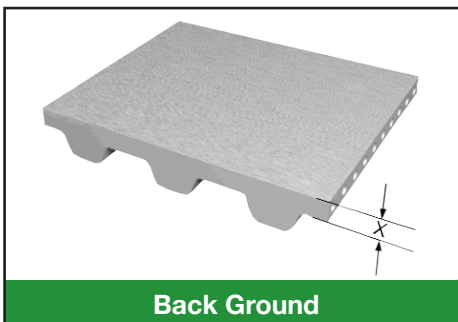

- Improved belt thickness tolerance
- Consistent belt back surface finish and friction
- Roughened belt back for spliced and welded "V" belts
- Standard for truly endless "BFX" belts > 720 mm
- Available for spliced and welded "V" belts > 450mm

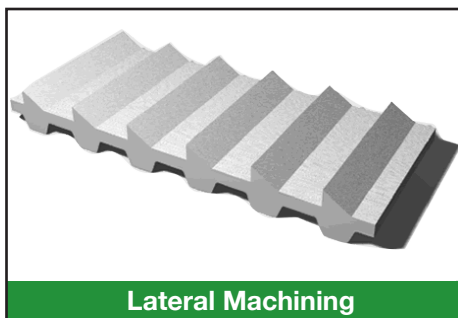

- Typically used with extra thick belt back "DR" or "T-Cover"
- Used for small parts conveying
- Used for incline conveying
- Standard and custom configurations available
- Increased flexibility

## TIMING BELT BACKINGS

# Machined Timing Belts

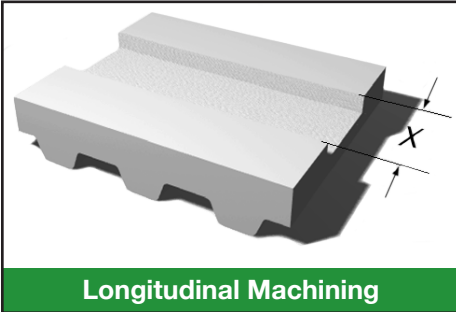

Longitudinal Machining

- Typically used with extra thick belt back "DR" or "T-Cover" for more design possibilities
- Used for longitudinal product conveying
- Combined with perforations for vacuum applications
- Used to align product during handling

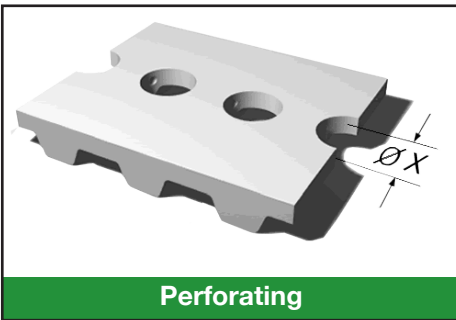

Perforating

- Used for vacuum applications
- Intricate hole patterns possible
- Used with tension free zones resulting in clean holes with no tension member interference
- Complex perforation shapes possible





ISO 9001 CERTIFIED COMPANY

# BRECOflex CO., L.L.C.

High Precision Drive Components

## Contact Us

222 Industrial Way West • Eatontown, NJ 07724

Tel: 732-460-9500 • Fax: 732-542-6725

[www.brecoflex.com](http://www.brecoflex.com) • e-mail: [info@brecoflex.com](mailto:info@brecoflex.com)

### Regional Sales Offices:

Atlanta	(770) 317-8745	Dallas	(214) 476-5650	Miami	(770) 317-8745	Richmond	(804) 387-5760
Bay Area	(661) 713 0121	Denver	(303) 470-7226	Milwaukee	(908) 461-6995	Seattle	(503) 781-3631
Baltimore	(804) 387-5760	Detroit	(908) 433-0036	Minneapolis	(908) 461-6973	Salt Lake City	(303) 470-7226
Boston	(603) 496-5833	Ft. Wayne	(908) 461-1168	Nashville	(732) 757-6647	San Antonio	(214) 476-5650
Buffalo	(412) 600-5632	Grand Rapids	(908) 461-1168	New York	(732) 829-7773	Toledo	(908) 433-0036
Charlotte	(908) 461-3937	Houston	(214) 476-5650	Philadelphia	(732) 829-7773	Toronto	(416) 476-7107
Chicago	(908) 461-6995	Indianapolis	(908) 461-2344	Phoenix	(480) 961-3846	Mexico City	+52 1 55 45335835
Cincinnati	(908) 461-2344	Las Vegas	(480) 961-3846	Portland	(503) 781-3631	Monterrey	+52 1 55 40840778
Cleveland	(412) 600-5632	Los Angeles	(661) 713-0121	Pittsburgh	(412) 600-5632	Guadalajara	+52 1 55 40949053

Copyright 2018 BRECOflex CO., L.L.C. • BRECO®, BRECOFLEX® & ATN® are registered trademarks of BRECO Antriebstechnik GmbH • ARC-POWER® is a registered trademark of BRECOflex CO., L.L.C. • Kevlar® is a registered trademark of DuPont Patents Pending • ESBAND® is a registered trademark of Max Schlatterer GmbH & Co. KG Patents Pending. Specifications are subject to change without prior notice.

All recommendations for the use of the products described herein and all other data or information set forth in this publication, whether concerning such products or otherwise, are furnished without any guarantee, warranty representations or inducement of any kind whether expressed or implied, including but not limited to warranties of merchantability and fitness for a particular purpose. BRECOflex CO., L.L.C. expressly disclaims liability under any theory, including without limitation, contract negligence, misrepresentation or breach of any obligation relating to the recommendation, data or information set forth herein. Readers and customers are encouraged to conduct their own test before using any product. Read its label and all related instructions. BRECOflex CO., L.L.C. reserves the right to make changes in the technical and dimensional specifications of its products without prior notice. Responsibility for expenses incurred as a result of product changes or discontinuance of a product lies solely with the purchaser.

Printed: 06/18