

Synchroflex动力传动集团

CONTI[®] SYNCHROFLEX
聚氨酯环形同步带
Product Range
CONTI[®] SYNCHROFLEX
Timing Belts

CONTI® SYNCHROFLEX

同步带 Timing Belts

先进的制造工艺和高性能的材料造就了优异的产品

由于坚持选用优质原料，以及耐磨聚氨酯外层与无延展的镀锌钢丝绳之间的粘接强度较高，CONTI® SYNCHROFLEX 聚氨酯同步带具有最好的动力传输性能。

高度灵活的生产工艺尤其适用于制造双面齿皮带和高精度齿型。得益于采用了一系列专业化合物和材料，该同步带可以在低温、无尘室和食品工业中运转。

Advanced manufacture and high-performance materials combine for product excellence

CONTI® SYNCHROFLEX Polyurethane Timing Belts deliver best-in-class power transmission performance thanks to the uncompromising selection of high-grade components and the superior bonding strength between the hard-wearing polyurethane shell and the constant-length galvanised steel tension members.

The highly flexible production process is particularly suitable for manufacturing double-sided belts and high accuracy profiles on the belt back. A range of specialist compounds and materials are available to enable operation at low temperatures, in clean rooms and in the food industry.

目录 Content

页码 Page	概要	General Information
4 – 5	制造工艺	Manufacturing processes
6 – 7	构造和性能	Construction and Properties
8 – 9	同步带类型	Timing Belt Types
10 – 11	抗静电同步带	Antistatic Timing Belts
12 – 13	第三代高功率版	High-power version GEN III
14 – 15	“E” 抗拉层	“E” tension member
16 – 18	皮带性能表	Belt performance table
19	公差	Tolerances
20	角传动装置	Angular drives
21	使用挡边带轮	Guiding belts with flanges
22	皮带张力仪	Belt tension gauges
23	齿隙形状	Tooth gap shapes
24 – 25	安全系数	Safety factors
26 – 29	初张力	Pre-tension force
30 – 31	计算依据	Basis of calculation
32 – 33	符号、单位和术语表	Glossary of Symbols, unit and terms
34 – 37	计算实例	Calculation example
	AT 型高性能同步带	AT high performance Timing Belts
38 – 39	AT 3 第三代	AT 3 GEN III
40 – 41	AT 3	AT 3
42 – 43	AT 5 第三代	AT 5 GEN III
44 – 45	AT 5	AT 5
46 – 47	AT 10 第三代	AT 10 GEN III
48 – 49	AT 10	AT 10
50 – 51	AT 20 第三代	AT 20 GEN III
52 – 53	AT 20	AT 20
	T型 同步带	T standard Timing Belts
54 – 55	T 2	T 2
56 – 57	T 2.5/T 2.5-DL	T 2.5/T 2.5-DL
58 – 59	T 5/T 5-DL	T 5/T 5-DL
60 – 61	T 10/T 10-DL	T 10/T 10-DL
62 – 63	T 20/T 20-DL	T 20/T 20-DL
	英制同步带	Imperial Timing Belts
64 – 65	M (MXL)	M (MXL)
	锯齿型同步带	Serrated Profile Timig Belts
66 – 67	K 1/K 1.5	K 1/K 1.5

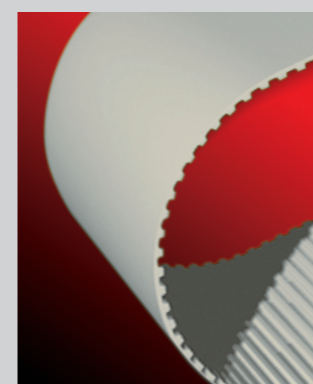

CONTI® SYNCHROFLEX

同步带 Timing Belts

制造工艺 Manufacturing processes

CONTI® SYNCHROFLEX 聚氨酯同步带由两部份组成，即浇注聚氨酯外层和优质钢丝绳抗拉层。这两种材料之间优异的粘合性能使得皮带的动力传输能力非常高。

制造工艺——浇注模压聚氨酯，具有以下优势：

- 浇注聚氨酯同步带准确代表了精密工程模具。整个皮带的节距精度高。该技术尤其适合于要求角精度高、运行平稳、转速快和使用寿命长的应用。
- 优异的线性度，加之高节距精度和重复性，允许通过调节钢丝张力来优化长度。
- 铸造方法与毛细管效应相结合，使得与钢制抗拉层之间的粘接强度异常高。
- 浇注聚氨酯工艺的重塑性较高，使得皮带具有良好的外形，且模塑的皮带节距较小。双面带和皮带背面的异形条板可以同时模压。
- 用这种工艺生产的皮带有效宽度达 300mm。
- 皮带长度为 55mm 至 6000mm（环形长度）。

CONTI® SYNCHROFLEX Polyurethane Timing Belts consist of two components – a cast Polyurethane shell and a high grade steel cord tension member. The excellent bond between the two materials results in a very high power transmission capacity.

The manufacturing process – cast moulded polyurethane – combines the following advantages:

- The cast polyurethane timing belt is an exact image of the precision engineered mould. High pitch accuracy is achieved over the entire belt. The technology is particularly suitable for applications requiring high levels of angular accuracy, smooth running characteristics, high rotational speeds and long life.
- Excellent linearity with high pitch accuracy and repeatability allows the length to be optimised by adjusting the cord tension.
- The casting method combines with the capillary effect, producing an exceptionally high strength bond with the steel tension members.
- The high reproduction quality of the cast polyurethane process enables fine contoured features and smaller belt pitches to be moulded. Double-sided belts and profiled flights on the back of the belt can be moulded simultaneously.
- The process produces an effective belt width of up to 300 mm.
- Belt lengths from 55 mm to 6000 mm endless length.

CONTI® SYNCHROFLEX 聚氨酯同步带广泛用于动力传输系统、伺服和运动控制、传输机和传输线路中的各种同步旋转运动传输应用。工作时的转速高达每分钟 20,000 转。

其应用包括：

- 办公设备
- 电子数据处理设备 (EDP)
- 纺织机械
- 木材加工机械
- 机床
- 印刷设备
- 泵
- 压缩机
- 建筑机械

CONTI® SYNCHROFLEX Polyurethane Timing Belts are used across a very wide range of applications for the transmission of synchronous rotary motion in power transmission systems, servo and motion controls, conveyors and transfer lines. They operate in a rotational speed range of up to 20,000 rpm.

Applications include:

- Office machinery
- Electronic data processing equipment (EDP)
- Textile machinery
- Wood processing machinery
- Machine tools
- Printing machinery
- Pumps
- Compressors
- Building machinery

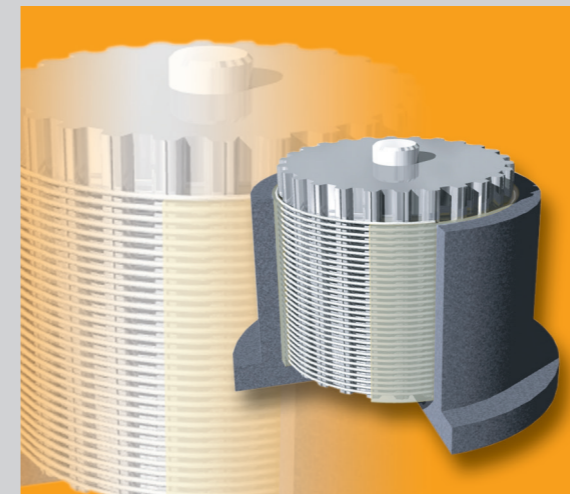
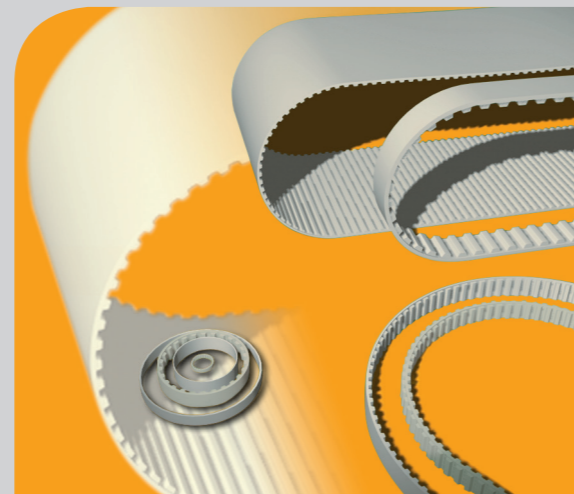

铸模，图为模芯上的螺旋缠绕抗拉层

Casting mould, illustrated with a spirally wound tension member on the mould core

准备脱模的同步带套筒，其中部分分离为几个皮带

Ready de-moulded timing belt sleeve, part of it separated into individual belts

CONTI® SYNCHROFLEX

构造 Constuction

CONTI® SYNCHROFLEX 聚氨酯同步带由耐磨聚氨酯和高强度钢丝抗拉层制成。这两种优质材料使得聚氨酯同步带延展率极低，且高度耐用。聚氨酯同步带纵向刚度非常高，连续工作时抗拉层不会伸长。只有在极高的负荷条件下，以及为预防起见，简单的试车之后，才会在损失少量张力的情况下重新张紧。

同步带具有温度耐受性，能够耐受-30°C至+80°C的环境温度。但在接近温度极限 (<-10°C 和 >+50°C) 的应用中，可能需要调整至适当的尺寸。对于特殊温度范围，可以选用其他皮带材料；例如 CONTI® SYNCHROFLEX 第三代聚氨酯同步带的温度耐受范围可以达到 +100°C。如需此类应用，请与我司技术专家联系。

CONTI® SYNCHROFLEX Polyurethane Timing Belts are manufactured from wear resistant Polyurethane and high tensile steel cord tension members. Both high quality materials combine to form the basis for dimensionally stable and highly durable polyurethane timing belts. Polyurethane timing belts have very high longitudinal stiffness and no post-elongation of the tension members is to be expected in continuous operation. Only under extreme loading conditions and as a precaution after a brief run-in, a small loss of tension may necessitate a once-only retensioning.

The timing belts are temperature resistant with ambient temperatures from -30°C to +80°C. However, applications close to these temperature limits (< -10°C and > +50°C), may require adapted dimensioning. For specific temperature ranges, optional belt materials are available; e.g. the CONTI® SYNCHROFLEX GEN III Polyurethane Timing Belt range is temperature resistant up to +100°C. Please contact our technical specialists for this type of application.

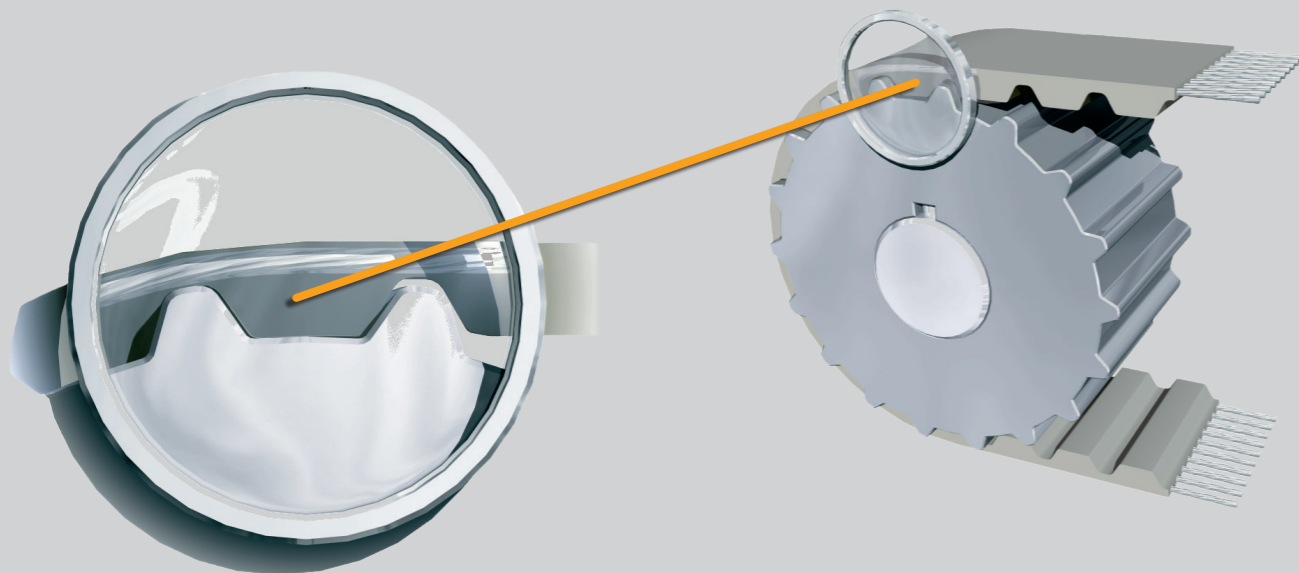

CONTI® SYNCHROFLEX 聚氨酯同步带采用的制造工艺保证了非常小的公差范围，确保在动力传输期间获得均匀的负荷分配。这些同步带同样适用于大扭矩传输和精密定位应用或二者相结合的应用。

CONTI® SYNCHROFLEX Polyurethane Timing Belts are manufactured using production methods that maintain very high tolerances to ensure a uniform load distribution during power transmission. They are equally suited for high torque transmission and precise positioning applications or the combination of both.

同步带 Timing Belts

性能 Properties

机械

- 精确啮合，同步运行
- 固定长度，无后延展
- 低噪音
- 耐磨
- 维护程度低
- 高挠性
- 定位和角度准确
- 耐疲劳，钢丝扩展率低抗拉层
- 皮带速度达 80 米/秒
- 成型尺寸小
- 动力重量比优异
- 初张力低
- 轴承负荷低
- 允许中心距较大
- 允许传动比高
- 效率可高达98%

mechanical

- positive fit, synchronous run
- constant length, no post-elongation
- low noise
- wear resistant
- low-maintenance
- highly flexible
- positional and angular accuracy
- fatigue resistant, low extension steel cord tension members
- belt speed up to 80 ms⁻¹
- small build sizes
- excellent power-to-weight ratio
- low pre-tension
- low bearing load
- permits large centre distances
- permits large transmission ratios
- high degree of efficiency, max. 98 %

化学

- 水解稳定
- 抗老化
- 可耐受温度范围为 -30° 至 +80°C, CONTI® SYNCHROFLEX 同步带第三代的设计耐受温度高达 100°C (相关信息见“构造”正文)
- 耐热带气候
- 耐纯油、油脂和汽油
- 耐某些酸碱

chemical

- hydrolysis stabilized
- resistant to aging
- temperature resistant from -30° to +80°C, design CONTI® SYNCHROFLEX Timing Belt GEN III up to 100°C (see information in the text "Construction")
- tropical climate resistant
- resistant against simple oils, fats and petrol
- resistant to some acids and alkalines

有关 CONTI® SYNCHROFLEX 聚氨酯同步带环境耐受特征的更多信息，请与康迪泰克传动系统有限公司联系。

For further information about the environmental resistance characteristics of CONTI® SYNCHROFLEX Polyurethane Timing Belts please contact the ContiTech Antriebssysteme GmbH.

CONTI® SYNCHROFLEX

同步带 Timing Belts

同步带类型 Timing Belt Types

AT型 高性能齿形

T型齿面的进一步发展，形成了AT齿型。这种皮带具有较大体积的齿形和更强的抗拉层，从而产生了较大的抗剪切强度。

其他优势：

- 凸齿啮合良好
- 高强度抗拉层
- 与T型齿型相比，性能提高达50%
- 精确的运动传输，外加同步带轮，减小了齿隙或无齿隙
- 减少啮合冲击
- 驱动装置尺寸紧凑

(第三代也具有此优势)

AT High capacity profile

Further development of the T profile resulted in the AT profile. This type of belt is characterised by the larger tooth shear strength resulting from the larger tooth volume and the stronger tension members.

Further advantages:

- favourable tooth mesh
- strengthened tension members for constant pitch
- Improved performance up to 50% as compared to the T profile
- precise transmission of movement in conjunction with synchronous pulleys with reduced or zero backlash
- reduction of meshing impacts or shocks
- compact drive dimensions

(also available in the GEN III version)

T型 标准齿形

按照DIN 7721，具有梯形齿型的同步带被视为是典型的标准同步带。

适用于以下应用：

- 标准驱动任务
- 双面皮带传输任务
- 弯曲应力大
- 回折传动

T Standard profile

The timing belt with a trapezoidal profile according to DIN 7721 is regarded as the classical standard timing belt.

Preferred use:

- for standard drive tasks
- transmission tasks with double-sided belts
- for high bending stress
- for drives with contraflexure

T型 双面齿形

DL同步带(双面)用于动力传输和交通技术。利用此同步带可以实现不同旋转方向的多轴驱动。两个齿侧都可以满载。

T in DL version

The DL timing belt (the belt is double-sided) is used in the power transmission and transport technology. Multiple-shaft drives with different rotational directions can be realised with this timing belt. Full load ability on both tooth sides.

英制齿型

根据DIN/ISO 5296，英制节距可用于以下尺寸：
M (MXL) = 2.032 mm

适用于：

- 英制单位应用

K型 公制锯齿型

适用于：

- 机械工艺好，要求尺寸小

Imperial profile

Imperial pitches according to DIN/ISO 5296 are available in the following size:
M (MXL) = 2.032 mm

Preferred use:

- Applications in imperial units

K Serrated metric pitch profile.

Preferred use:

- Fine mechanical technology requiring small dimensions

CONTI® SYNCHROFLEX

抗静电同步带 Antistatic Timing Belts

抗静电同步带 Antistatic Timing Belts

通过以下方面实现 CONTI® SYNCHROFLEX 聚氨酯同步带的抗静电性能:

1. 抗静电涂层

无论是否带有纺织饰面，处理后的皮带表面及侧面均涂有导电涂层

2. 抗静电聚氨酯混合物

一种特殊的导电聚氨酯混合物（皮带最大长度为700 mm）

其他长度可由客户指定

抗静电同步带的颜色：黑色

表面电阻 $R \leq 10^6 \Omega$

The antistatic properties of CONTI® SYNCHROFLEX Polyurethane Timing Belts are achieved by:

1. antistatic coating

A post-process application of an electrically conductive coating on all sides of the belts with or without textile facing

2. antistatic polyurethane mixture

A special conductive polyurethane mixture (max. belt length to 700 mm)

other lengths on request.

Colour of antistatic timing belts: black.

Surface resistance $R \leq 10^6 \Omega$

应用/使用

对于要求有防止静电（ESD）的场合均可使用 CONTI® SYNCHROFLEX 抗静电聚氨酯同步带，例如在易燃易爆环境中输送电子部件、驱动装置和/或传输设备。

静电荷

由于两个齿接触的不断分合，涉及同步带的地方可能会产生静电，例如带轮和同步带之间。该静电放电可能很大，在放电时，可能会增大着火的危险系数。静电值取决于同步带、同步带轮、张紧轮和/或支承轮所使用的材料。随着皮带速度、张力和接触面宽度的增加，静电放电的危险也会增大。

抗静电性能

CONTI® SYNCHROFLEX 抗静电聚氨酯同步带可始终避免产生静电。

质量保证

利用符合 ISO 9563 要求的试验设备对导电率进行测量。根据要求，可以在齿面上来测试同步带抗静电的耐磨性。由于长时间运转可能导致表面磨损，抗静电同步带的导电率可能会下降，因此必须定期对电阻值进行检查。在爆炸危险性较高的环境下使用皮带时，请咨询技术专家。

订单实例

CONTI® SYNCHROFLEX 同步带25 T 5/630 EL-PU抗静电涂层

关于可用长度，请联系康迪泰克传动系统有限公司。

Application/Use

Antistatic CONTI® SYNCHROFLEX Polyurethane Timing Belts are used where electrostatic discharge (ESD) is not desired or is prohibited, e.g. for the transport of electronic components, for drives and/or conveying equipment in an inflammable or explosive environment.

Electrostatic charges

The build up of static electricity, due to the continual separation of two contact surfaces, can be expected where timing belts are involved, e.g. between pulley and timing belt. This static electric charge can be considerable and may increase the danger of ignition at the moment of discharge. The value of the static electric charge is dependent on the materials used for the timing belt, synchronous pulleys, tension rollers and/or support rollers. The risk of ESD rises as the belt speed, belt tension and the contact surface width increase.

Antistatic properties

Antistatic CONTI® SYNCHROFLEX Polyurethane Timing Belts consistently avoid the formation of static electric charges.

Quality assurance

Conductivity is measured using test equipment meeting ISO 9563 requirements. Upon request, the wear resistance of the antistatic layer can be checked on test timing belts with an antistatic facing. Due to the fact that extended operation will result in probable surface wear, the conductivity of the antistatic timing belts may deteriorate and regular checks of the resistance values are essential. When belts are to be used in environments with a high likelihood of explosion, please contact our technical specialists for advice.

Order example

CONTI® SYNCHROFLEX Timing Belt 25 T 5/630 EL-PU antistatic coated

For available lengths, please contact the ContiTech Antriebssysteme GmbH.

CONTI® SYNCHROFLEX

同步带 Timing Belts

第三代高功率版 High-power version GEN III

CONTI® SYNCHROFLEX 同步带(SFX)
AT 第三代

高强度底层基础

高强度钢丝抗拉层与耐磨聚氨酯的组合使用，为 CONTI® SYNCHROFLEX 聚氨酯同步带提供了稳定的尺寸和极为耐用的高性能。由于采用了领先一步的技术，该产品具有以下优异特点：

- 稳定长度，无延展
- 尺寸稳定性高
- 大扭矩传输
- 运转噪音低
- 免维护
- 无需润滑
- 化学药品和机械耐受程度高

每一代各不相同。
第三代更好！

值得进一步集中开发 AT 系列 CONTI® SYNCHROFLEX 第三代聚氨酯同步带的动力驱动装置，因为与 AT 标准版相比，第三代新品动力传输增加了25%。另一项成本优势：CONTI® SYNCHROFLEX 第三代所有聚氨酯同步带均支持使用标准 AT 带轮。

我们愿意从复杂程度到最小的细节，为每一种产品提供解决方案的同时实施技术改进。双线抗拉层排列和较高的包装密度造就了 CONTI® SYNCHROFLEX 第三代 AT 和 ATP 系列聚氨酯同步带。

高性能的聚氨酯专为 CONTI® SYNCHROFLEX第三代聚氨酯同步带的使用而设计，与标准版相比，大大提高了基准测试结果。其中一大好处就是：硬度增大，线路工程师可以借助大量的承重凸齿进行工作。

CONTI® SYNCHROFLEX Timing Belt (SFX)
AT GEN III

A powerful basis

The combination of high tensile steel cord tension members and wear resistant polyurethane forms the basis for dimensionally stable and extremely durable high-performance CONTI® SYNCHROFLEX polyurethane timing belts. A convincing technology with excellent product features that include:

- constant length, no post-elongation
- high dimensional stability
- high-torque transmission
- quiet running
- maintenance-free
- lubrication-free
- highly chemical resistant and mechanically durable

Each generation is different.
GEN III is better!

It was worth its while to focus on further developing the power drives of the AT range CONTI® SYNCHROFLEX GEN III polyurethane timing belts because the new GEN III generation excels in a 25% increase in power transmission compared with the AT standard. Another economic bonus: all CONTI® SYNCHROFLEX GEN III polyurethane timing belts support the use of standard AT pulleys.

We agree that advancement is synonymous to providing solutions for every product at a level of sophistication down to the smallest detail. A bifilar tension member arrangement and a higher packing density translates this into the CONTI® SYNCHROFLEX GEN III polyurethane timing belt for the AT and ATP ranges.

The high-performance polyurethane designed for dedicated use with the CONTI® SYNCHROFLEX GEN III polyurethane timing belts yields greatly improved benchmark results compared with the standard. One of the benefits is that its increased hardness allows line engineers to count on a larger number of load-carrying teeth.

CONTI® SYNCHROFLEX 第三代——
与标准版相比，动力传输提高 25%：

- 由于钢丝缠绕得更紧，张力 F_{zul} 最大增加到 +45%。
- 重新设计的双（S和Z）钢丝线绳平衡，便于更好地进行控制，防止皮带跑偏
- 挡边摩擦减少
- 运转噪音降低，同样的性能，带宽更窄
- $F_{spez} +25\%$
- 寿命更长
- 均布凸齿的载荷力——增大达30%
- 最高温度可达 +100°C
(对于接近温度范围极限的性能值，请寻求技术支持。)

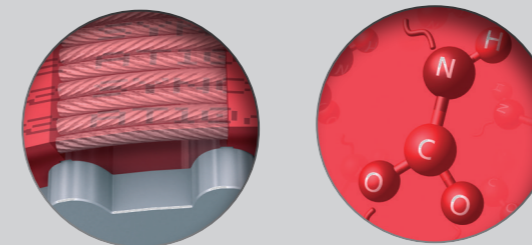
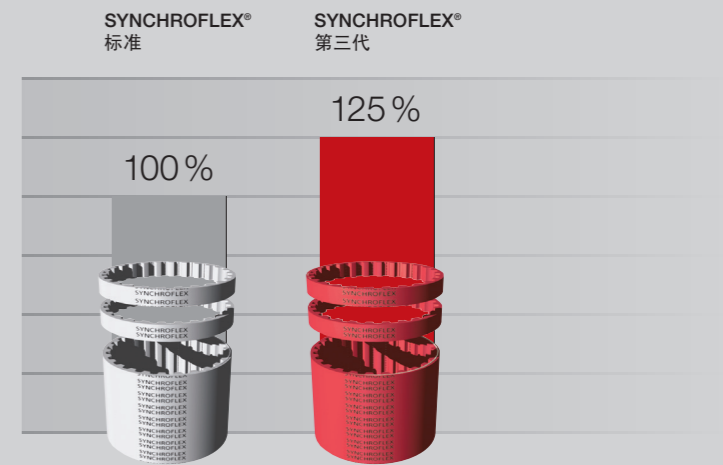

双线绳布置

新型高性能
聚氨酯

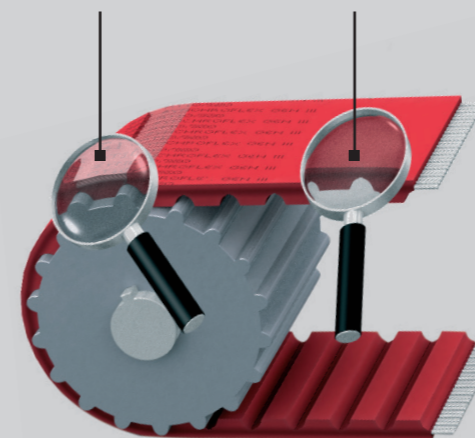

CONTI® SYNCHROFLEX GEN III –
with up to 25 % greater power transmission
compared with the AT standard:

- increased tensile force F_{zul} to max. +45 % due to closer wound cords
- redesigned bifilar steel (S and Z) cord balance for better tracking
- reduced flange friction
- lower running noise with narrower belt width for equal performance
- $F_{spez} +25\%$
- longer life
- load bearing teeth force distribution – increased by up to 30 %
- temperature range up to +100°C
(For performance values close to the range limit, please ask for technical support.)

CONTI® SYNCHROFLEX

“E” 抗拉层 “E” tension member

高挠性张力层 Highly flexible tension inserts

每一根丝绳的直径越小，整个抗拉层的挠性就越高！我们利用这一关系开发出了带有“E”抗拉层的 CONTI® SYNCHROFLEX 聚氨酯同步带。

“E”抗拉层的横截面积由几束小直径钢丝线绳组成，每一根钢丝线绳都具有优异的抗弯疲劳特性。CONTI® SYNCHROFLEX 聚氨酯同步带的整体挠性大大提高，尤其适合于直径较小的带轮和张紧轮；与标准抗拉层相比，凸齿的最小数量和/或带轮的最小直径均可减小 30%。建议将带“E”抗拉层的同步带用于经常反向弯曲的多轴驱动装置。

总结：

- 钢丝中钢丝直径较小
- 动态性能更高
- 粘接强度和抗弯疲劳强度极高
- 带轮和张紧轮直径更小
- 在标准直径的同步带轮上运转。

如需在极端条件下使用，请联系我公司以获取技术支持。

The smaller the diameter of each single wire, the more flexible the overall tension member is! This relationship led us to develop CONTI® SYNCHROFLEX Polyurethane Timing Belts with “E” tension members.

The cross sectional area of the “E” tension member comprises several strands of smaller diameter wires, each with excellent bending fatigue characteristics. With much improved overall flexibility CONTI® SYNCHROFLEX Polyurethane Timing Belts are particularly suited to smaller diameter pulleys and tension rollers; the minimum number of teeth and/or minimum diameter of the pulleys can be reduced by up to 30% compared with standard tension members. Timing belts with “E” tension members are recommended for multi-shaft drive applications with frequent reverse bending.

Summary:

- smaller diameter individual wires in the steel cord
- higher dynamic capabilities
- extremely high bonding and bending fatigue strength
- smaller pulley and tension roller diameter
- runs on standard diameter timing pulleys.

For applications under extreme conditions, please contact our technical support.

应用信息：
覆膜钢丝芯绳

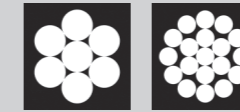

钢丝的直径越小，整个同步带的挠性就越高。

可用版本：

- 节距 AT 3（标准）、AT 5（第三代标准）、AT 10、T 5、T 10、T 20
- 所选节距的所有标准带长
- 所有计算均根据所选标准带进行

Application information:

Steel cord tension members encapsulated in polyurethane

The smaller the diameter of the individual wire, the more flexible the whole timing belt.

Available versions:

- for the pitches AT 3 (standard), AT 5 (Gen III standard), AT 10, T 5, T 10, T 20
- all standard belt lengths for the chosen pitch
- all calculations as per the standard belt chosen

带“E”抗拉层的同步带，最小凸齿数

Timing belts with “E” tension members, minimum numbers of teeth

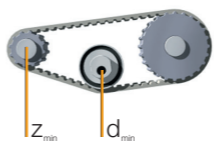
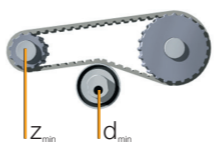
驱动类型 Drive type			AT 3 (标准)	AT 5 (第三代 标准)	AT 10	T 5	T 10	T 20
无反向弯曲 without contraflexure 	同步带轮 Timing pulley	z_{min}	15	14	12	10	10	12
	张紧轮（光面）， 在凸齿上运转 Tension roller (smooth), running on teeth	d_{min} [mm]	20	20	50	20	50	80
有反向弯曲 with contraflexure 	同步带轮 Timing pulley	z_{min}	20	20	20	12	15	20
	张紧轮（光面）， 在皮带背面运转 Tension roller (smooth), running on the back of the belt	d_{min} [mm]	20	50	80	20	50	120

CONTI® SYNCHROFLEX

同步带 Timing Belts

皮带性能表 Belt performance table

AT 3 第三代

动力传输:	≤ 6 kW	Power transmission:	≤ 6 kW
转速:	大约 20.000 转/分	Rotational speed:	approx. 20.000 min ⁻¹
圆周速度:	大约 80 米/秒	Peripheral speed:	approx. 80 ms ⁻¹
同步带轮:	15齿以上	Timing pulleys:	from z=15
应用 (实例):	小型动力传动装置、 处理技术	Applications (Example):	small power drives, Handling technology

AT 10 第三代

动力传输:	≤ 87 kW	Power transmission:	≤ 87 kW
转速:	大约 10.000 转/分	Rotational speed:	approx. 10.000 min ⁻¹
圆周速度:	大约 60 米/秒	Peripheral speed:	approx. 60 ms ⁻¹
同步带轮:	15齿以上	Timing pulleys:	from z=15
应用 (实例):	施工机械、泵、造纸机、压 缩机、压土机、纺织机械、 辊道驱动装置	Applications (Example):	Construction machines, Pumps, Paper-making machines, Compressors compactors, Textile machinery, Roller-table drives

AT 3

动力传输:	≤ 5 kW	Power transmission:	≤ 5 kW
转速:	大约 20.000 转/分	Rotational speed:	approx. 20.000 min ⁻¹
圆周速度:	大约 80 米/秒	Peripheral speed:	approx. 80 ms ⁻¹
同步带轮:	15齿以上	Timing pulleys:	from z=15
应用 (实例):	小型动力传动装置、 处理技术	Applications (Example):	small power drives, Handling technology

AT 10

动力传输:	≤ 70 kW	Power transmission:	≤ 70 kW
转速:	大约 10.000 转/分	Rotational speed:	approx. 10.000 min ⁻¹
圆周速度:	大约 60 米/秒	Peripheral speed:	approx. 60 ms ⁻¹
同步带轮:	15齿以上	Timing pulleys:	from z=15
应用 (实例):	施工机械、泵、造纸机、压 缩机、压土机、纺织机械、 辊道驱动装置	Applications (Example):	Construction machines, Pumps, Paper-making machines, Compressors compactors, Textile machinery, Roller-table drives

AT 5 第三代

动力传输:	≤ 18 kW	Power transmission:	≤ 18 kW
转速:	大约 10.000 转/分	Rotational speed:	approx. 10.000 min ⁻¹
圆周速度:	大约 80 米/秒	Peripheral speed:	approx. 80 ms ⁻¹
同步带轮:	14齿以上	Timing pulleys:	from z=14
应用 (实例):	机床、泵、纺织机械	Applications (Example):	Machine tools, Pumps, Textile machinery

AT 20 第三代

动力传输:	可能超过 250 kW	Power transmission:	possible beyond 250 kW
转速:	大约 6.500 转/分	Rotational speed:	approx. 6.500 min ⁻¹
圆周速度:	大约 40 米/秒	Peripheral speed:	approx. 40 ms ⁻¹
同步带轮:	18齿以上	Timing pulleys:	from z=18
应用 (实例):	重型驱动装置、纺织机械、 印刷机、机床	Applications (Example):	Heavy-duty drives, Textile machinery, Printing machine, Machine tools

AT 5

动力传输:	≤ 15 kW	Power transmission:	≤ 15 kW
转速:	大约 10.000 转/分	Rotational speed:	approx. 10.000 min ⁻¹
圆周速度:	大约 80 米/秒	Peripheral speed:	approx. 80 ms ⁻¹
同步带轮:	15齿以上	Timing pulleys:	from z=15
应用 (实例):	机床、泵、纺织机械	Applications (Example):	Machine tools, Pumps, Textile machinery

AT 20

动力传输:	可能超过 200 kW	Power transmission:	possible beyond 200 kW
转速:	大约 6.500 转/分	Rotational speed:	approx. 6.500 min ⁻¹
圆周速度:	大约 40 米/秒	Peripheral speed:	approx. 40 ms ⁻¹
同步带轮:	18齿以上	Timing pulleys:	from z=18
应用 (实例):	重型驱动装置、纺织机械、 印刷机、机床	Applications (Example):	Heavy-duty drives, Textile machinery, Printing Machine, Machine tools

CONTI® SYNCHROFLEX

同步带 Timing Belts

皮带性能表 Belt performance table

K 1,5; T 2; M; T 2,5

动力传输:	≤ 0.5 kW	Power transmission:	≤ 0.5 kW
转速:	大约 20.000 转/分	Rotational speed:	approx. 20.000 min ⁻¹
圆周速度:	大约 80 米/秒	Peripheral speed:	approx. 80 ms ⁻¹
同步带轮:	10齿以上	Timing pulleys:	from z=10
应用 (实例):	精密机器驱动装置、 电影摄像机驱动装置、 定位驱动装置	Applications (Example):	Precision machine drives, Film camera drives, Positioning drives

T 5

动力传输:	≤ 5 kW	Power transmission:	≤ 5 kW
转速:	大约 10.000 转/分	Rotational speed:	approx. 10.000 min ⁻¹
圆周速度:	大约 80 米/秒	Peripheral speed:	approx. 80 ms ⁻¹
同步带轮:	12齿以上	Timing pulleys:	from z=12
应用 (实例):	办公设备、家电、 定位和调节驱动装置	Applications (Example):	Office machinery, Home appliances, Positioning and regulating drives

T 10

动力传输:	≤ 30 kW	Power transmission:	≤ 30 kW
转速:	大约 10.000 转/分	Rotational speed:	approx. 10.000 min ⁻¹
圆周速度:	大约 60 米/秒	Peripheral speed:	approx. 60 ms ⁻¹
同步带轮:	12齿以上	Timing pulleys:	from z=12
应用 (实例):	机床、主副驱动、 纺织机械、印刷设备	Applications (Example):	Machine tools, Main and subsidiary drives, Textile machinery, Printing machinery

T 20

动力传输:	≤ 100 kW	Power transmission:	up to approx. 100 kW
转速:	大约 6.500 转/分	Rotational speed:	approx. 6.500 min ⁻¹
圆周速度:	大约 40 米/秒	Peripheral speed:	approx. 40 ms ⁻¹
同步带轮:	15齿以上	Timing pulleys:	from z=15
应用 (实例):	重型施工机械、造纸机、 泵、压缩机、压土机、 纺织机械	Applications (Example):	Heavy Construction machines, Paper-making machines, Pumps, Compressors compactors, Textile machinery

备注: 特殊同步带的设计可以提高每分钟转速和圆周速度参数。
Remark: Special timing belt designs allow the rpm and peripheral speed parameters to be increased.

公差 Tolerances

标准版长度公差 CONTI® SYNCHROFLEX 聚氨酯同步带

带长按照DIN 7721进行测量, 与中心距有关。

Length tolerances for standard CONTI® SYNCHROFLEX Polyurethane Timing Belts

Belt length measurement is carried out to DIN 7721, in relation to the centre distance.

带长 Belt length	与中心距有关的长度公差 Length tolerance in relation to centre distance
达 up to 320 mm	±0.15 mm
320 – 630 mm	±0.18 mm
630 – 1000 mm	±0.25 mm
1000 – 1960 mm	±0.40 mm
1960 – 3500 mm	±0.50 mm
3500 – 4500 mm	±0.80 mm
4500 – 6000 mm	±1.20 mm

标准版宽度公差 CONTI® SYNCHROFLEX 聚氨酯同步带

Width tolerances for standard CONTI® SYNCHROFLEX Polyurethane Timing Belts

类型/组别 Type/group	达 up to 50 mm	50 – 100 mm	带宽超过 100 mm, 用%表示 over 100 mm in % of Belt width
K 1	± 0.3 mm	± 0.5 mm	± 0.5 %
K 1.5	± 0.3 mm	± 0.5 mm	± 0.5 %
T 2	± 0.3 mm	± 0.5 mm	± 0.5 %
M (MXL)	± 0.3 mm	± 0.5 mm	± 0.5 %
T 2.5	± 0.3 mm	± 0.5 mm	± 0.5 %
T 5	± 0.3 mm	± 0.5 mm	± 0.5 %
T 5-DL	± 0.3 mm	± 0.5 mm	± 0.5 %
T 10	± 0.5 mm	± 0.5 mm	± 0.5 %
T 10-DL	± 0.5 mm	± 0.5 mm	± 0.5 %
T 20	± 1.0 mm	± 1.0 mm	± 1.0 %
T 20-DL	± 1.0 mm	± 1.0 mm	± 1.0 %
AT 3	± 0.3 mm	± 0.5 mm	± 0.5 %
AT 5	± 0.5 mm	± 0.5 mm	± 0.5 %
AT 10	± 1.0 mm	± 1.0 mm	± 1.0 %
AT 20	± 1.0 mm	± 1.0 mm	± 1.0 %

请注意: 可根据客户需求提供特殊抗拉层的公差。

Please note: Tolerance for special tension members upon request.

CONTI® SYNCHROFLEX

同步带 Timing Belts

扭向传动装置 Angular drives

CONTI® SYNCHROFLEX 同步带可以用作扭向传动装置。考虑到同步带只能交叉（扭曲）消除流失效应。

CONTI® SYNCHROFLEX Timing Belts can be applied as angular drives. Take into consideration that the timing belt can only be crossed (twisted). Eliminates the run-off effect.

2 轴扭向传动装置
Angular drive with 2 axes



3 轴扭向传动装置
Angular drive with 3 axes

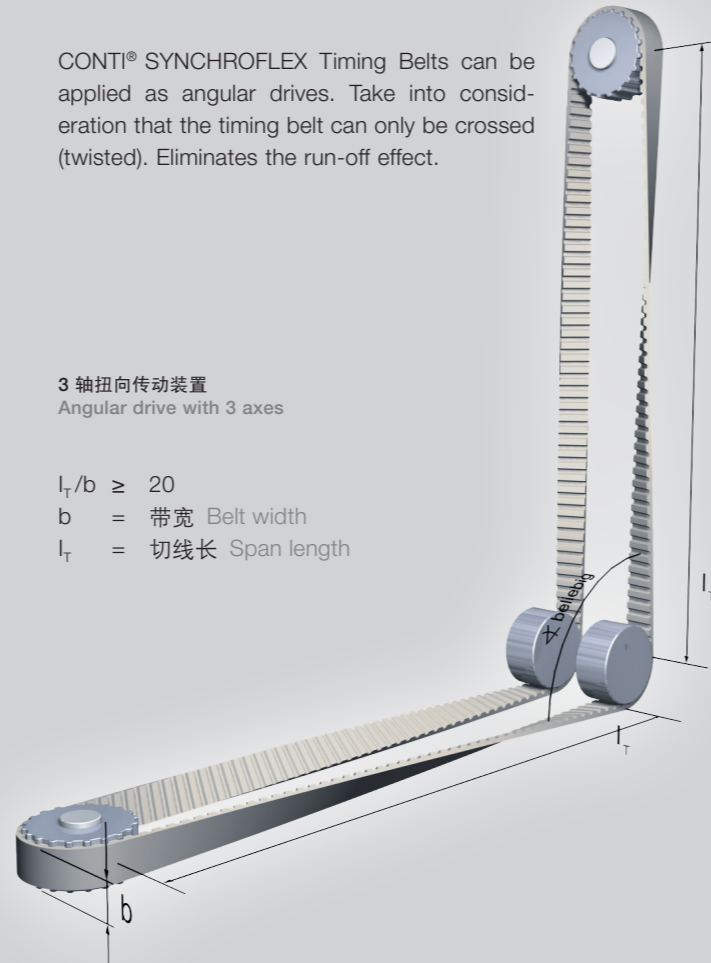

$l_T/b \geq 20$
b = 带宽 Belt width
 l_T = 切线长 Span length

使用交叉同步带时，外部抗拉层的伸长率比内部构件要高。由于边缘带的拉伸较大，因此抗拉层中皮带的允许比例圆周力减小。

With crossed timing belt applications the outer tension members suffer a higher elongation than the inner ones. Due to the larger elongation in the edge zone the permitted proportional circumferential force for the belt in the tension members is reduced.

当 l_T/b 的比率 ≥ 20 时，不需要减小功率或采取特殊措施。

No power reductions or special measures are necessary at a ratio of $l_T/b \geq 20$.

当 l_T/b 的比例 < 20 时，请咨询我司技术部。

At a required ratio of $l_T/b < 20$ please contact our technical department for advice.

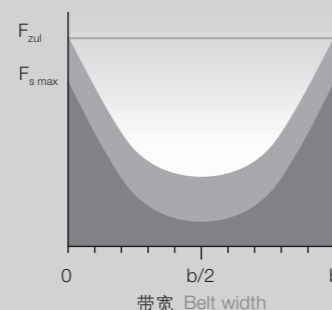

— F_{zul} 容许张力
Admissible tensile force
■ F_u 其它离心力
The remaining peripheral force
■ F_s 因交叉产生的张力
Tensile force due to crossing

使用挡边带轮 Guiding belts with flanges

必须对同步带进行引导，以消除侧向流失效应。通常由挡边进行引导。优化皮带带轮挡边的布置可以尽量减少侧向力，降低摩擦损耗。

Timing belts must be guided to eliminate the lateral run-off effect. This is normally done by flanges. Minimum lateral forces and low frictional losses can be resulted by the optimum arrangement of the belt guidance.

为此，可进行以下操作：

- 将同步带布置在较大自由跨长的下游（进给长度 (a) 不得低于带宽 b 的 5 倍）
- 将导槽布置在驱动带轮中（中心距较短的两轴驱动装置更好）
- 引导低传输带轮（多轴驱动装置更好）
- 导槽位于张紧轮之上
 - 张紧轮位于松跨侧
 - 布置在皮带背侧：考虑反向弯曲时的最小直径
 - 布置在皮带凸齿侧：接触弧面长度，最少 3 个凸齿
 - 跨长中心最好有旋转方向变化
 - 条件：张紧轮与带轮之间的最小跨长 (a) 不应低于带宽 b 的 5 倍
- 确保所有带轮的轴向平行度和对齐性较高，以获得最佳引导特性。
- 为成本起见，虑及功能可靠性后，还可以让挡边适应更小的带轮。

For this purpose, the following possibilities are available:

- Timing belt guidance downstream of a large free span length (infeed length (a) should not be less than 5 times belt width b)
- Guidance at the drive pulley (preferable for two shaft drives with short centre distance)
- Guide for low-transmission pulleys (preferably for multiple-shaft drives)
- Guidance on the tension rollers
 - Tension roller arrangement in the slack span side
 - with arrangement on the belt back side: consider minimum diameter with contraflexure
 - with arrangement on the belt toothed side: Length of arc of contact, min. 3 teeth
 - with changing rotational directions preferable in the span length centre
 - Condition: Minimum span length (a) between tension roller and pulley should not be less than 5 times belt width b
- Ensure high axis parallelity and flush alignment of all pulleys to achieve optimum guiding features.
- For cost reasons it is possible to fit flanges also to the smaller pulley after taking the functional reliability into consideration.

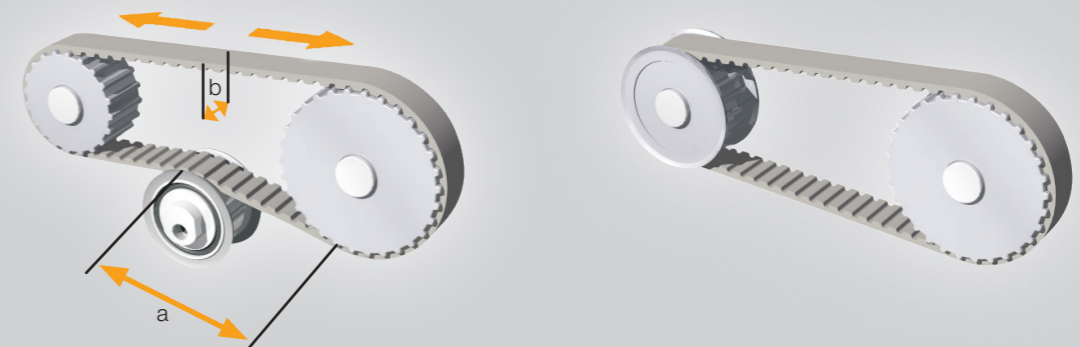

在两线布置中使用 CONTI® SYNCHROFLEX 聚氨酯同步带是优化皮带带槽的理想前提。

The application of CONTI® SYNCHROFLEX polyurethane timing belts in two-filament arrangement is the ideal prerequisite for an optimum belt guidance.

CONTI® SYNCHROFLEX

同步带 Timing Belts

皮带张力仪 Belt tension gauges

设定正确的初张力

建议采用频率测量方法来检查同步带的初始张力。在此方法中，在设定振动时通过测量皮带跨度的固有频率来获得初始张力。所需的计算公式和具体皮带数据见第28页。

Setting the correct pre-tension force

It is recommended that the initial tension of timing belts is checked by using the frequency measuring method. In this method the initial tension is obtained by measuring the natural frequency of the belt span when set vibrating. The calculation formulas and specific belt data needed for this are given on page 28.



CONTI® 张力仪 VSM-1 和 VSM-3
CONTI® Tension Gauges VSM-1, VSM-3

齿隙形状 Tooth gap shapes

同步带为正面安装的驱动部件。与各个同步带轮一起工作，不会产生滑动。此外，可以对 CONTI® SYNCHROFLEX 同步带驱动装置进行优化，实现运动传输，并且产生的齿侧间隙较小。对于某些齿型和节距，可以使用 SE 或零间隙，尤其是高精度驱动装置。请联系我们获得技术指导。

Timing belts are positive fitted drive elements. They work slippage-free with the respective synchronising pulleys. CONTI® SYNCHROFLEX timing belt drives can be optimised additionally for a movement transmission with a low flank backlash.

For some profiles and pitches, the SE or zero gap can be used for especially high accuracy drives. Please contact us for technical advice.

- 应用前提：
同步带与带轮之间的节距匹配。
- 节距匹配的影响因素：
 - 初张力
 - 啮合齿数量 (z_e)
 - 负荷比（转速、动态性能等）
 - 制造公差

- Prerequisites for the application:
Pitch matching between timing belts and pulley.
- Influencing factors of the pitch matching:
 - Pre-tension force
 - No. of teeth in mesh (z_e)
 - Load rate
(rotational speed, dynamic behaviour ...)
 - Manufacturing tolerances

实例 T10 的齿隙形状

Tooth gap shapes for Example T10

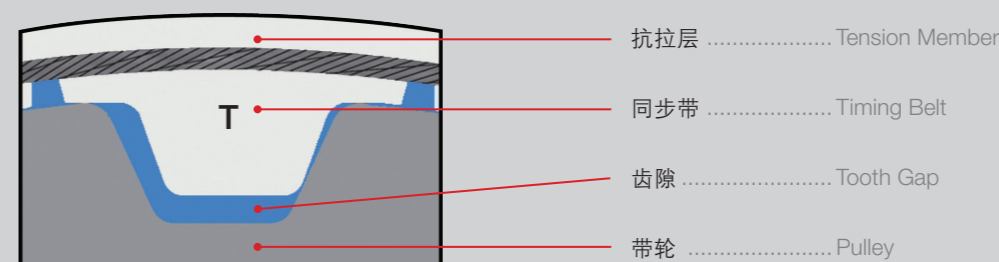

正常齿隙
Normal Backlash Tooth Gap

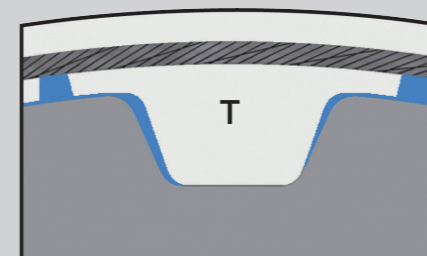

间隙减小的“SE”齿隙
Reduced Backlash “SE” Tooth Gap

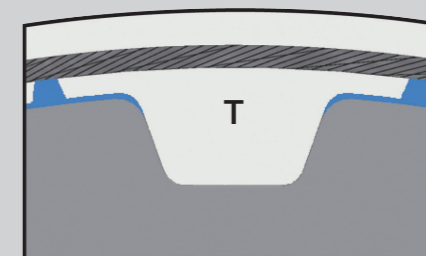

“0”齿隙
Zero Backlash “0” Tooth Gap

CONTI® SYNCHROFLEX

同步带 Timing Belts

安全系数 Safety factors

在不利操作条件下，只要未超过凸齿抗剪强度、张力线强度和挠性的允许值，同步带的宽度均正确。我们的产品目录中对经过可靠证明和通过台架试验和实践所获结果确认的负荷极限进行了说明。仅传输速度较高的驱动装置需要安全系数。

工程师了解并正确估计驱动期间出现的不利负荷类型很重要。在齿轮啮合传动下，即使采用传动构件同步带也会出现短时的过载问题。针对该问题的一些指导方法如下：

额定操作

针对额定负荷的操作条件设计同步带。额定负荷是指传动装置在正常条件下以额定速度传输扭矩或动力时的操作条件。

启动特征

a) 驱动侧：必须考虑启动条件下传动机的最大扭矩。如三相鼠笼电机的启动扭矩为额定值的 2 至 2.5 倍。

b) 驱动侧：必要时，必须考虑在启动特征下影响驱动部分同步带的“初始扭矩”。

检查转速 $n=0$ 时的负荷状况 a) 或 b)。

制动

可能需要确定制动是否会通过同步带产生满负荷，是否会超过额定操作或启动时所产生的瞬时负荷。在制动过程中，应考虑到可能出现的扭矩反转。

The width of a timing belt is correct when the permissible values for tooth shear strength, tension cord strength and flexibility are not exceeded under unfavourable operating conditions. In our catalogue, load limits are stated which have been reliably proven and confirmed by bench tests and results obtained in practice. A safety factor is only required for drives with transmission into higher speed.

It is important, that the unfavourable load types occurring in the drive are known resp. correctly estimated by the engineer. With a positive fit transmission, even short-period overloads act via the timing belt being the drive member. Some instructions to this issue:

Rated operation

Design timing belts for the operating condition of the rated load. The rated load is the operating condition at which the drive should transmit the torque or the power at rated speeds under normal conditions.

Start-up characteristics

a) Drive side: The max. torque of the drive machine under start-up conditions is to be taken into consideration. The start-up torque, e.g. for three-phase squirrel cage motors amounts to 2 to 2.5 times the rated value.

b) On the drive side: If necessary, „initial torques“ effective to the drive part timing belt are to be taken into consideration under start-up characteristics.

Check load case a) or b) with rotational speed $n=0$.

Braking

It might have to be defined whether braking leads to loads which fully act via the timing belt and possibly exceed the type of load produced by the rated operation or the start-up characteristics. During braking a possible torque reversal should be taken into consideration.

非稳定（负荷变化、冲击负荷）

除额定负荷之外，共振和冲击负荷可能对作为传输构件的同步带产生影响。以插图为例，将计算所得带宽系数增大 1.3。

Unevennesses (load variations, shock loads)

In addition to the rated load, superimposed vibration and shock loads could act on the timing belt as the transmission member. For the illustrated example, increase the calculated belt width by the factor of 1.3.

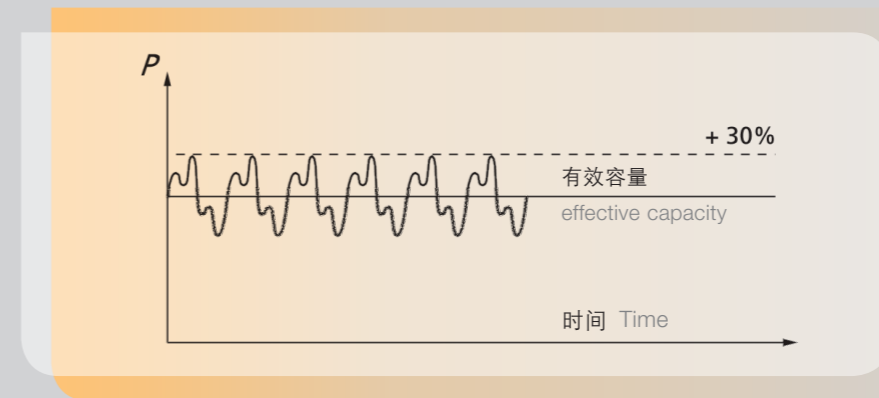

惯性矩

传动装置中的惯性矩和/或离心质量通常会使得运转性能保持不变。视加减速特征而定，需要区分并检查惯性矩是否会对同步带产生其他负荷。

Moments of inertia

Moments of inertia and/or centrifugal masses in the drives generally create a uniform running behaviour. Depending on the acceleration and deceleration characteristic it has to be differentiated and checked whether the moments of inertia create an additional load on the timing belt.

增速传送

增速传送要用到以下安全系数：

Step-up transmission

The following safety factors are to be applied for step-up transmissions:

$i = 0.66$ 至 $up\ to\ 1.00$	$S = 1.1$
$i = 0.40$ 至 $up\ to\ 0.66$	$S = 1.2$
$i < 0.40$	$S = 1.3$

在制动过程中，可能会发生扭矩反转，从而将减速比变成增速传动。

During braking a torque reversal may occur which would change a reduction ration into a step-up drive.

CONTI® SYNCHROFLEX

同步带 Timing Belts

初张力 Pre-tension force

施加初张力的目的在于保证松边的最小张力，以确保凸齿平稳地与从动带轮啮合。

一般情况下，只能将初张力尽量设高。所需跨度初拉力 F_V 取决于最大离心力 F_U 、带长 L_B （凸齿数 Z_B ）和传动配置。

Pre-tension is intended to guarantee a minimum tensioning force at the slack span side to ensure smooth tooth meshing into the driven pulley.

Generally, the pre-tension should only be set as high as necessary. The necessary pre-tension force of the spans F_V depends on the max. peripheral force F_U , the belt length L_B (number of teeth Z_B) and the drive configuration.

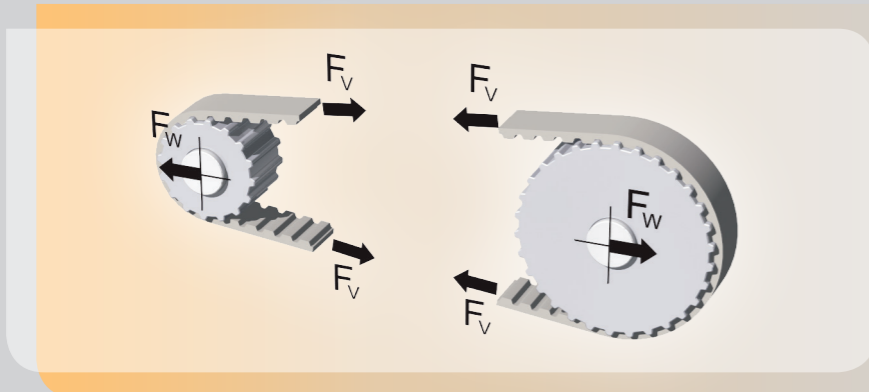

表中的建议值是指各跨度的初张力设置。

The recommendations shown in the table refer to the pre-tension force setting per span.

传动配制 Drive configuration	各跨度的初张力 Pre-tension force of each individual span
两轴传动 Two-shaft drive $Z_B < 60$ $60 \leq Z_B < 150$ $Z_B > 150$	$F_V = 1/3 F_U$ $F_V = 1/2 F_U$ $F_V = 2/3 F_U$
多轴传动 Multiple-shaft drive $I_{\text{负荷跨度 Load span}} \leq I_{\text{松边跨度 Slack span}}$ $I_{\text{Lasttrum Load span}} > I_{\text{松边跨度 Slack span}}$	$F_V = F_U$ $F_V > F_U$
线性传动 Linear drive $F_V \geq F_U$	

无论在何种情况下，张力线强度均为跨度负荷的最高极限。考虑到特别是多轴和线性传动装置，需要增大与负荷跨度力有关的初张力和离心力。

In every case, the tension cord strength is the top limit of the span load. Take into consideration that especially with multiple-shaft and linear drives, an addition of the pre-tension force and the peripheral force in relation to the load span force is to be expected.

影响因素

皮带刚度

啮合凸齿相互作用（尤其是在松跨时）产生的摩擦力增大了跨度力，反过来增加了伸长度。这一影响可能会导致与从动带轮相连的轮齿啮合跨度松弛，从而导致皮带跳出。

由于伸长率直接取决于皮带刚度，钢丝绳抗拉层的刚度较高时，初拉力相对较低。

Influencing factors

Belt stiffness

Friction forces created by the interaction of the tooth mesh (especially at the slack span) intensify the span forces, which in turn increase the degree of elongation. This influence may lead to the slack span tooth mesh butting against the driven pulley, thereby causing the belt to jump.

Elongation being directly depending on the belt stiffness, the high stiffness of the steel cord tension members permits a comparably low pre-tension.

离心力

离心力按比例作用于负荷跨度的伸长率，即如果过度松弛，则可以通过与离心力相匹配的初张力将其抵消掉。

Peripheral force

The peripheral force acts in proportion to the elongation of the load span, i.e. excessive slackening of the slack span can be counter-acted by a pre-tension matched to the peripheral force.

带长

因离心力和摩擦力作用产生的皮带拉伸率大致也与带长成比例。因此，是否会上跑或跳出受带长影响较大。即使是在离心力较大的情况下，随着摩擦力的产生，非常短同步带只有少量伸长，因此即使初张力较小，也不会出现凸齿向上跑或跳出的危险。相反，对于较短的同步带，如果带轮出现圆周偏差可能导致初拉力波动较大，由此会出现极大的峰值。

Belt length

Belt elongation resulting from the effect of the peripheral force and the friction forces is also approximately in proportion to the belt length. Therefore, the tendency of running up or jumping is considerably influenced by the belt length. Even under high peripheral forces with the resulting friction forces, a very short timing belt will elongate to only a small degree, so that even when subject to low pre-tension forces there will be no danger of running up or jumping of teeth. On the contrary, with short timing belts peripheral deviations of the pulleys could cause heavy pre-tension fluctuations and, as a result, extreme peak values.

跨长比例

尤其是在多轴传动情况下，通常其负荷跨度明显长于松跨一侧。所以，当负荷跨度轻微伸长时，便会导致跨侧非常松弛。因此，这一比率的跨度初张力应比离心力要大。

Proportion of the span lengths

Especially with multiple-shaft drives the load span is often markedly longer than the slack span side. For this reason, a slight elongation of the load span results in a very unfavourable slack on the span side. Therefore, the pre-tension force of spans of such ratios should be higher than the peripheral force.

精确运动传输

在离心力相同的情况下，选择跨度初张力时，在 CONTI® SYNCHROFLEX 同步带反向运转的情况下，传输精度可能较高。

Precise transmission of movement

There is a high transmission accuracy possible in the reverse operation with CONTI® SYNCHROFLEX Timing Belts, when the span pre-tension forces are selected in the same size of the peripheral force.

CONTI® SYNCHROFLEX

同步带 Timing Belts

初张力 Pre-tension force

初拉力设定错误的后果

初拉力过小

- 松跨侧的凸齿跑到从动带轮的齿轮之上或盖住从动带轮的凸齿
- 因啮合过程中的摩擦力作用，导致面部磨损
- 由于完全覆盖，过度伸长迫使凸齿发生破损

初拉力过大

- 轴的轴承负荷高
- 可传输功率下降
- 皮带凸齿磨损

利用频率测量仪进行测量

振动皮带跨度的固有频率可以通过各种皮带张力测量仪进行测量。可以根据测得的固有频率计算跨度的初张力：

$$F_v = 4 \cdot m \cdot l_T^2 \cdot f^2$$

如果预设了初拉力，可以计算相应的固有频率：

$$f = \sqrt{\frac{F_v}{4 \cdot m \cdot l_T^2}}$$

f: 振动频率 (单位: Hz)
m: 每米长的皮带质量 (单位: kg/m)
l_T: 受振动影响的滚筒跨长 (单位: m)
F_v: 跨度力 (单位: N)

有关各种测量仪表，请与您的销售伙伴联系。

Consequences of faulty pre-tension setting

too low pre-tension

- the teeth of the slack span side run up on or override the teeth of the driven pulley
- Wear on the faces caused by the friction force during meshing
- Forced breakage by excessive elongation due to full overriding

excessive pre-tension

- high bearing load of the shafts
- Reduction of the transmittable power
- Wear and tear at the belt tooth

Measuring with frequency measuring meter

The intrinsic frequency of a vibrating belt span can be measured by means of various Mulco belt tension measuring meters. The pre-tension force of the span can be calculated from the measured intrinsic frequency:

The corresponding intrinsic frequency can be calculated, if the pre-tension is preset:

f: Frequency of the variations in Hz
m: Mass of the belt per meter length in kg/m
l_T: drum span length subject to vibration in m
F_v: Span force in N

Please contact your sales partner for the various measuring meters.

一般信息

设计

- 在传输配置中，至少设计一个可调轴，规划一个可调张紧轮（无弹簧负荷），以固定中心距
- 轴承必须精确固定
- 注意同步带轮平行运转和齐平对应的重要性

输送/储存

- 收到之后，立即将同步带开箱，并将其储存于室温条件下干燥处的圆形位置
- 不要弯曲

安装

- 在同步带松弛时，将其装在带轮上，不施加任何力量
- 在中心距固定的情况下进行安装时，不要施加任何力量，如有必要，与同步带轮一起安装
- 按照“初拉力”一章的说明预设初拉力
- 固定可调轴，避免其产生滑动
- 勿夹紧挡边之间的同步带

操作

- 保护传动装置，使其免受粉尘、污物、周围热介质以及酸碱的影响
- 考虑环境温度（见聚氨酯同步带的特征）

General informations

Design

- In the transmission configuration, design at least one adjustable axis, plan one adjustable tension roller (not spring-loaded) for fix centre distances
- the bearing has to be absolutely rigid
- Note the importance of a parallel run and flush alignment of the timing pulleys

Transport/storing

- Upon receipt, unpack the timing belt immediately and store in circular position in a dry place at room temperature
- Do not bend

Mounting

- Fit timing belts on the pulleys when slack without exerting any force
- Exert no force when fitting with fixed centre distances if necessary, fit together with timing pulleys
- Apply pre-tensioning force according to the chapter „Pre-tension“
- secure adjustable axis against slippage
- Do not clamp the timing belt between the flanges

Operation

- Protect the drives against dust, dirt, hot surrounding media as well as acids and alkalis
- Take into consideration the ambient temperatures (see Characteristics of polyurethane timing belts)

CONTI® SYNCHROFLEX

同步带 Timing Belts

计算依据 Basis of calculation

如果同时满足以下条件：凸齿强度 (1)、抗拉层拉伸强度 (2) 和挠性(3)，则可以对免维护同步带进行操作。

Providing the following conditions of tooth strength (1st), tension member tensile strength (2nd) and flexibility (3rd) are met, then a maintenance-free timing belt operation can be expected.

1. 轮齿抗剪强度 特定凸齿抗剪强度

1. Tooth shear strength specific tooth shear strength

力的分布 Force distribution

负荷分布 Load distribution

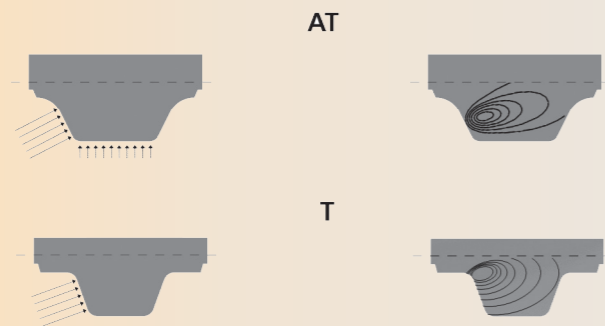

特定凸齿抗剪强度取决于转速。特定凸齿最大抗剪强度为连续工作条件下带齿所能承受的极限负荷。其值在各类同步带的表格中均有说明。只要不超过凸齿容许抗剪强度，同步带驱动装置的设计均为正确。通常来说，不需要特殊的安全系数，见“安全系数”一章。

The specific tooth shear strength depends on the rotational speed. The maximum specific tooth shear strength is the limit load the belt tooth can bear in continuous operation. The values are stated in tables for each timing belt type. The timing belt drive is correctly designed, when not exceeding the admissible tooth shear strength. Generally, a special safety factor is not necessary, see chapter „Safety factors“.

多个带齿在带轮中啮合时，工作负荷可以更有效地进行分布。

The working loads can be distributed more effectively with more belt teeth meshing in the pulley.

由于 CONTI® SYNCHROFLEX 同步带的节距精度较高，通常情况下，可以用啮合的12个带齿进行计算，除非实际啮合的数量低于12个。

Due to the high pitch accuracy of CONTI® SYNCHROFLEX Timing Belts, generally, it can be calculated with 12 belt teeth in mesh, unless there are less than that number actually in mesh.

2. 抗拉层强度 皮带横切面上的容许拉伸应力

2. Tension member strength Admissible tensile stress on the belt's cross-section

在运行条件下，只要不超过钢丝绳抗拉层的最大容许张力，同步带的设计均为正确。表中 F_{zul} 值是指固定负荷。

The timing belt is designed correctly, when the maximum admissible tensile force in the steel cord tension members is not exceeded under operation conditions. The table values for F_{zul} refer to the constant loading.

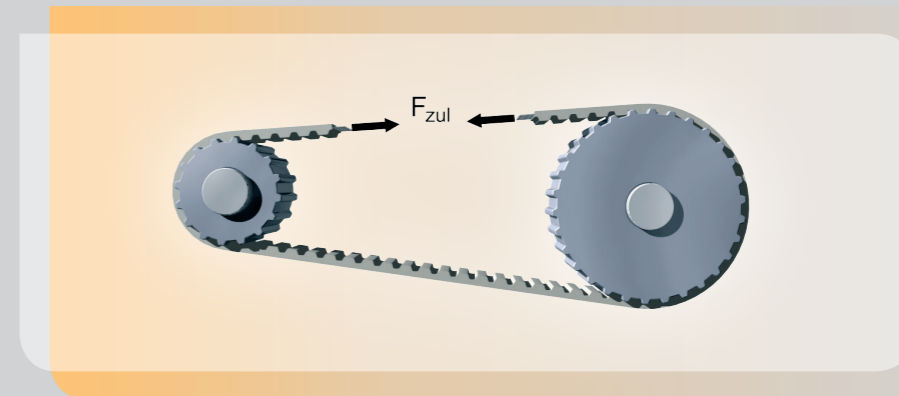

3. 挠性 最低凸齿数、最小直径

3. Flexibility Minimum number of teeth, minimum diameter

无故障运行所需的建议最低凸齿数和/或最小直径取决于所选的皮带类型。使用“有反向弯曲”的皮带装置时（例如，由于是张紧轮），尤其应考虑到最低凸齿数和/或最小直径较大。

The recommended minimum number of teeth and/or the minimum diameter for a malfunction-free operation depends on the selected belt type. Take especially into consideration that the minimum number of teeth and/or the minimum diameter is higher when using a belt arrangement „with contraflexure“ (e. g. due to a tension roller).

无反向弯曲的驱动方式
Drive layout without contraflexure

有反向弯曲的驱动方式
Drive layout with contraflexure

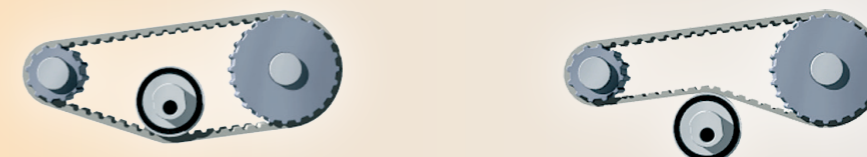

CONTI® SYNCHROFLEX

同步带 Timing Belts

符号、单位和术语表

Glossary of symbols, units and terms

符号 Symbol	单位 Unit	定义 Definition	
a	[mm]	中心距	Centre distance
b	[mm]	带宽	Belt width
B	[mm]	带轮宽	Pulley width
d	[mm]	带孔带轮	Bore pulley
d ₀	[mm]	节距圆直径	Pitch circle diameter
d _k	[mm]	外径	Outside diameter
f _e	[s ⁻¹]	频率	Frequency
F _U	[N]	离心力	Peripheral force
F _{U spez} F _{U spec}	[N/cm]	单位齿力	specific tooth force
F _{U zul}	[N]	容许张力	admissible tensile force
F _V	[N]	初张力	Pre-tension force
F _W	[N]	轴力	Shaft force
i		比率	Ratio
J	[kgm ²]	承重扭矩	Load bearing torque
L _B	[mm]	带长	Belt length
L _T	[mm]	切线长	Span length
m	[kg]	负荷	Load
M	[Nm]	扭矩	Torque
M _B	[Nm]	加速转矩	Acceleration torque
M _{spez} M _{spec}	[Ncm/cm]	单位转矩	specific torque
n	[min ⁻¹]	转速	Rotational speed
ρ	[kg/dm ³]	密度	Density
P	[kW]	功率	Power
P _{spez}	[W/cm]	单位功率	specific Power
t	[mm]	节距	Pitch
t _B	[s]	加速时间	Acceleration time
v	[m/s]	速度	Speed
w	[s ⁻¹]	角速度	Angular speed
z _B		带齿数量	Number of belt teeth
z		i = 1 时的带齿数量	Number of teeth with i = 1
z _e		啮合轮齿数量	Number of teeth in mesh
z ₁		小带轮凸齿数量	Number of teeth of the small pulley
z ₂		大带轮凸齿数量	Number of teeth of the large pulley

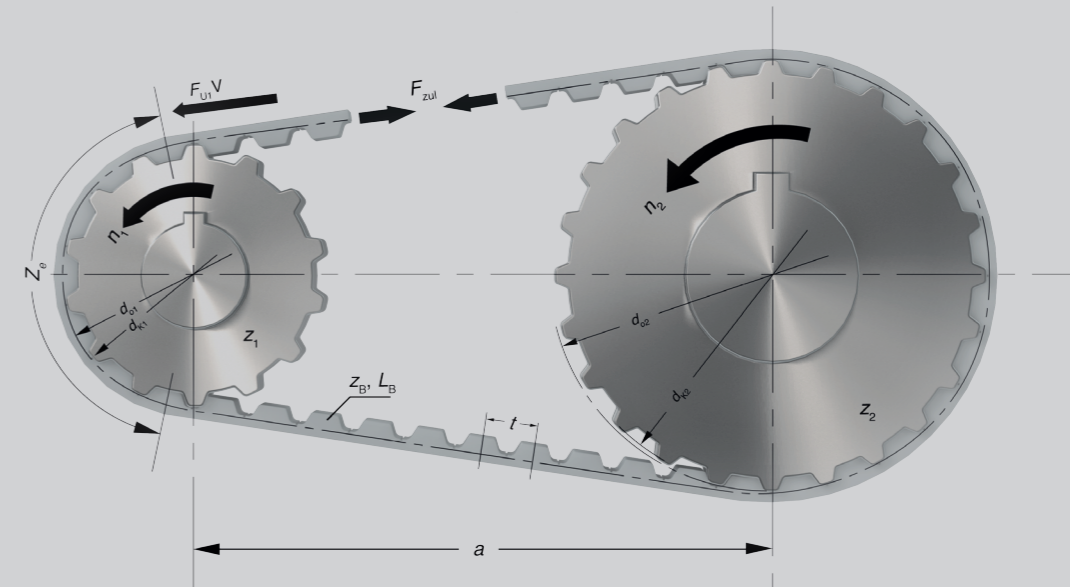

离心力 Peripheral force	扭矩 Torque	功率 Power	i = 1 时的带长 Belt Length for i = 1
$F_U = \frac{2 \cdot 10^3 \cdot M}{d_0}$ $= \frac{19.1 \cdot 10^6 \cdot P}{n \cdot d_0}$ $= \frac{10^3 \cdot P}{v}$	$M = \frac{d_0 \cdot F_U}{2 \cdot 10^3}$ $= \frac{9.55 \cdot 10^3 \cdot P}{n}$ $= \frac{d_0 \cdot P}{2 \cdot v}$	$P = \frac{M \cdot n}{9.55 \cdot 10^3}$ $= \frac{F_U \cdot d_0 \cdot n}{19.1 \cdot 10^6}$ $= \frac{F_U \cdot v}{10^3}$	$L_B = 2a + \pi \cdot d_0$ $= 2a + z \cdot t$
角速度 Angular speed	转速 Rotational speed	速度 Speed	节距圆直径 Pitch circle diameter
$\omega = \frac{\pi \cdot n}{30}$	$n = \frac{19.1 \cdot 10^3 \cdot v}{d_0}$	$v = \frac{d_0 \cdot n}{19.1 \cdot 10^3}$	$d_0 = \frac{z \cdot t}{\pi}$
加速转矩 Acceleration torque	承重扭矩 Load bearing torque		
$M_B = \frac{J \cdot \Delta n}{9.55 \cdot t_B}$	$J = 98.2 \cdot 10^{-15} \cdot B \cdot \rho \cdot (d_k^4 - d^4)$		

利用此处提到的尺寸运用所有方程。
Apply all equations with the dimensions mentioned here.

CONTI® SYNCHROFLEX

同步带 Timing Belts

计算实例 Calculation example

任务

针对重型传输任务，必须设计辊道驱动装置。在启动条件下，对同步带施加大约 2.5 倍的转矩。

应用条件如下：

给定条件

功率	P = 10 kW
公称速度	n = 800 min ⁻¹
启动转矩	M = 300 Nm
比率	i = 1
齿数	z = 25
中心距	a = 625 mm

要求

确定同步带节距，并计算带宽。

Task

A roll table drive must be designed for heavy conveying duties. Under start-up conditions approx. 2.5 times the running torque is exerted on the timing belt.

The application conditions are:

Given

Power	P = 10 kW
Nominal speed	n = 800 min ⁻¹
Start-up torque	M = 300 Nm
Ratio	i = 1
Number of teeth	z = 25
Centre distance	a = 625 mm

Required

The timing belt pitch is to be determined and the belt width is to be calculated.

公式 Formula

$$b = \frac{1000 \cdot P}{z_1 \cdot z_e \cdot P_{spez\ spec}} \quad M[Nm]$$

$$b = \frac{100 \cdot M}{z_1 \cdot z_e \cdot M_{spez\ spec}} \quad P[kW]$$

$$F_U = \frac{2 \cdot 10^3 \cdot M}{d_0} \quad F_U [N]$$

$$L = 2 \cdot a + z \cdot t \quad [mm]$$

$$d_0 = \frac{z \cdot t}{\pi} \quad [mm]$$

如何进行

带长
齿型预选：AT10.利用公式计算带长：

$$L = 2 \cdot a + z \cdot t = 2 \cdot 625 + 25 \cdot 10 = 1500 \text{ mm}$$

带宽计算

1. 凸齿抗剪强度

计算时将用到 $z_e = 12$ (见计算依据)。利用功率方程中的公称速度计算带宽。

$$b = \frac{1000 \cdot P}{z_1 \cdot z_e \cdot P_{spez\ spec}} = \frac{1000 \cdot 10}{25 \cdot 12 \cdot 6.96} = 4.79 \text{ cm} = 47.9 \text{ mm}$$

转速n=0时计算启动转矩下的带宽。

$$b = \frac{100 \cdot M}{z_1 \cdot z_e \cdot M_{spez\ spec}} = \frac{100 \cdot 300}{25 \cdot 12 \cdot 11.70} = 8.54 \text{ cm} = 85.4 \text{ mm}$$

带宽由最苛刻的负荷条件决定。选择：第二大标准带宽 $b = 100 \text{ mm}$ 。

2. 抗拉层强度

可借助以下通用数据计算相应的离心力：

$$F_U = \frac{2 \cdot 10^3 \cdot M}{d_0} = \frac{2 \cdot 10^3 \cdot M}{79.58} = 7539 \text{ N} < 16000 \text{ N}$$

带宽为100 mm时，AT 10 的表值 F_{zul} 为16000N。因此，抗拉层的安全系数满足需要。

3. 挠性

设计为“无反向弯曲”的传动装置。遵循表中的最低齿数。

结果：

带宽为100 mm时驱动装置设计正确。因此，可以进行免维护操作。
订购代码：CONTI® SYNCHROFLEX 100 AT 10/1500

How to proceed

Belt length
Profile preselection: AT10. Calculation of the belt length with formula:

Calculation of the belt width

1. Tooth shear strength

In the calculation $z_e = 12$ will be used (see basis of calculation). Calculation of the belt width with the nominal speed from the power equations.

Calculation of the belt width under start-up torque when rotational speed $n = 0$.

The belt width is to be determined from the least favourable load conditions. Selected: the next larger standard belt width $b = 100 \text{ mm}$.

2. Tension member strength

The corresponding peripheral force can be calculated from the general data supplied:

The tabular value F_{zul} for AT 10 with 100 mm belt width is 16000 N. Thus, there is a sufficient tension member safety factor.

3. Flexibility

The design is a drive „without contraflexure“. The minimum number of teeth according to the table is adhered to.

Result:

The drive is correctly designed with a belt width of 100 mm. A maintenance-free operation can be expected.
Order code: CONTI® SYNCHROFLEX 100 AT 10/1500

CONTI® SYNCHROFLEX

同步带 Timing Belts

计算实例: Calculation example

用于输送 CONTI SYNCHROFLEX® 聚氨酯同步带

输送皮带应优先使用机头传动装置设计。需输送的货物可以有一个或多个负荷。可以将多个负荷看作一个线路负荷。

离心力 F_U 的计算
根据总体输送负荷，可以导出传动带轮总成所需的牵引力或离心力 F_U ：

$$F_U = 9.81 \cdot m \cdot \mu$$

传动带轮的离心力	F_U [N]
待运物品的质量	m [kg]
同步带相对于底板的摩擦系数	μ

依照摩擦系数（滑动摩擦），可以假设以下数值：

钢/PUR 92 邵氏 A 硬度	0.6 – 0.7
PE/PUR	0.3 – 0.4

一般来说，摩擦系数范围较大。必要时，需要进行试验。可能会出现错误和遗漏。

力/伸长性能信息

图中的网格表面显示了运转条件下同步带的力/伸长性能。由于皮带伸长，被输送产品间的间距朝传动带轮增加。

中心 $s_1 < s_2$

CONTI SYNCHROFLEX® Polyurethane Timing Belts used for transportation

Transport belts should be designed preferably with a head drive. The goods to be transported can consist of one or more individual loads. Multiple individual loads can be seen as a line load.

Calculation of the Peripheral force F_U
From the overall transport load, the required haul-off force or the peripheral force F_U for the drive pulley assemblies can be derived:

$$F_U = 9.81 \cdot m \cdot \mu$$

Peripheral force at the drive pulley.	F_U [N]
Mass of the items to be transported	m [kg]
Friction factor of the timing belt in relation to the bed plate	μ

As friction factor μ (slide friction), the following values can be assumed:

Steel/PUR 92 Shore A	0.6 – 0.7
PE/PUR	0.3 – 0.4

In general, friction factors show large ranges. Trials should be carried out, if necessary. Errors and omissions excepted.

Information on the force/elongation behaviour

The grid surface in the picture shows the force/elongation behaviour in the timing belt under operating conditions. The individual spacing between the transported products increases towards the drive pulley due to belt elongation.

Centre $s_1 < s_2$

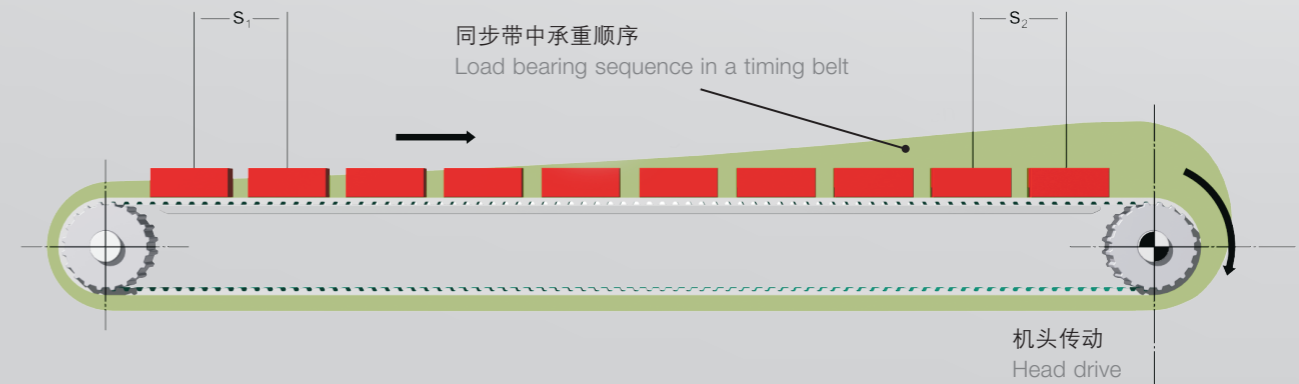

初张力
建议设定输送同步带的初拉力，以便在运转条件下松跨侧始终保持残余预紧力。初拉力需要达到以下要求：

$$F_v > 0.5 \cdot F_U$$

计算带宽 b

$$b = \frac{F_U}{z_e \cdot F_{Uspez}} \quad F_U [N]$$

F_U : 离心力（已计算）

F_{Uspez} : 带齿单位负荷

z_e : 连续联组皮带的啮合齿数：
 $z_{emax} = 12$

Pre-tension force
We recommend to set the pre-tension force in the transport timing belt such that a residual pre-tension force is always maintained on the slack span side under operating conditions. The following pre-tension force is required:

$$F_v > 0.5 \cdot F_U$$

Calculating the Belt width b

$$b = \frac{F_U}{z_e \cdot F_{Uspez}} \quad F_U [N]$$

F_U : peripheral force (calculated)

F_{Uspez} : specific load of the belt teeth

z_e : number of teeth in mesh for endless joined belts:
 $z_{emax} = 12$

AT 型高性能同步带

AT high performance Timing Belts

AT 3 第三代 技术数据 Technical data

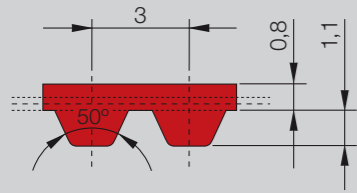

AT 3 Gen III

CONTI® SYNCHROFLEX 同步带 (SFX) AT 3 第三代

公制节距和梯形齿的高性能 AT 齿型。

标准版:

- 单面
- 红色高性能聚氨酯
- 高密度钢丝绳抗拉层
- 双线结构钢丝绳抗拉层
- 高挠性结构钢丝绳抗拉层

FA: 背面较厚

FN: 皮带背面的齿型

CONTI® SYNCHROFLEX Timing Belt (SFX) AT 3 GEN III

High performance AT profile with metric pitches and trapezoidal teeth.

Standard version:

- single-sided
- high performance polyurethane in red colour
- steel cord tension members with high density
- steel cord tension members in two-filament construction
- steel cord tension members in highly flexible construction

FA: with bigger back thickness

FN: with profiles on the back of the belt

类型 Type 第三代	/ 长度* / Length*	齿数 Number of teeth
AT 3 /	150	50
AT 3 /	201	67
AT 3 /	201 FN68	67
AT 3 /	252	84
AT 3 /	267	89
AT 3 /	270	90
AT 3 /	300	100
AT 3 /	351	117
AT 3 /	399	133
AT 3 /	417	139
AT 3 /	450	150
AT 3 /	486 FA	162
AT 3 /	486 FN18	162
AT 3 /	501	167
AT 3 /	549	183
AT 3 /	600	200
AT 3 /	639	213
AT 3 /	648	216
AT 3 /	648 FN24	216
AT 3 /	714	238
AT 3 /	816	272
AT 3 /	816 FA	272
AT 3 /	900	300
AT 3 /	1011	337

首选带宽* (单位: mm):

Preferred belt width* in mm:

6, 10, 16, 25, 32

*可按客户要求提供其他尺寸。

* Other dimensions upon request.

1. 凸齿抗剪强度 (单位带齿强度)

Tooth shear strength (specific belt tooth strength)

每分钟转速 R.p.m. n [min ⁻¹]	F _{Uspez} F _{Uspec} [N/cm]	M _{spez} M _{spec} [Ncm/cm]	P _{spez} P _{spec} [W/cm]
0	40.43	1.93	0.00
20	40.00	1.91	0.04
40	39.60	1.89	0.08
60	39.21	1.87	0.12
80	38.85	1.86	0.16
100	38.50	1.84	0.19
150	37.70	1.80	0.28
200	36.98	1.77	0.37
300	35.69	1.70	0.54
400	34.60	1.65	0.69
500	33.64	1.61	0.84
600	32.79	1.57	0.98
700	32.03	1.53	1.12
800	31.34	1.50	1.25
900	30.70	1.47	1.38
1000	30.11	1.44	1.51
1100	29.56	1.41	1.63
1200	29.05	1.39	1.74
1300	28.58	1.36	1.86
1400	28.13	1.34	1.97
1500	27.70	1.32	2.08
1600	27.30	1.30	2.18
1700	26.91	1.29	2.29
1800	26.55	1.27	2.39
1900	26.20	1.25	2.49
2000	25.88	1.24	2.59
2200	25.25	1.21	2.78
2400	24.66	1.18	2.96
2500	24.40	1.17	3.05
2600	24.14	1.15	3.14

每分钟转速 R.p.m. n [min ⁻¹]	F _{Uspez} F _{Uspec} [N/cm]	M _{spez} M _{spec} [Ncm/cm]	P _{spez} P _{spec} [W/cm]
2800	23.63	1.13	3.31
3000	23.16	1.11	3.47
3200	22.71	1.09	3.63
3400	22.30	1.07	3.79
3600	21.90	1.05	3.94
3800	21.53	1.03	4.09
4000	21.16	1.01	4.23
4500	20.34	0.97	4.58
5000	19.59	0.94	4.90
5500	18.90	0.90	5.20
6000	18.28	0.87	5.48
6500	17.69	0.85	5.75
7000	17.15	0.82	6.00
7500	16.65	0.80	6.24
8000	16.18	0.77	6.47
8500	15.74	0.75	6.69
9000	15.31	0.73	6.89
9500	14.91	0.71	7.08
10000	14.54	0.69	7.27
12000	13.19	0.63	7.91
15000	11.53	0.55	8.64
18000	10.16	0.49	9.15
20000	9.38	0.45	9.37

转速超过每分钟20000转和/或带速超过80m/s时, 需要对传动装置进行特殊设计。请咨询我公司。

Rotational speeds over 20000 rpm and/or belt speeds over 80 m/s need special drive designs. Please ask our advice.

2. 抗拉层强度 (皮带允许张力 F_{zul})、带重

Tension member strength (permitted tensile force of the belt F_{zul}). Belt weight

带宽	Belt width	b	[mm]	6	10	16	25	32
抗拉层强度	Tension member strength	F _{zul}	[N]	330	599	1002	1608	2079
带重	Belt weight	AT 3 第三代	[kg/m]	0.016	0.026	0.042	0.065	0.083

3. 挠性 (最低齿数、最小直径)

Flexibility (Minimum numbers of teeth, minimum diameter)

无反向弯曲 without contraflexure		同步带轮 Timing pulley	Z _{min}	15
		张紧轮 (光面), 齿轮上运行 Tension roller (smooth), running on teeth	d _{min} [mm]	20
有反向弯曲 with contraflexure		同步带轮 Timing pulley	Z _{min}	20
		张紧轮 (光面), 在皮带背面运转 Tension roller (smooth), running on the back of the belt	d _{min} [mm]	20

订购实例 Order example

CONTI® SYNCHROFLEX 同步带
CONTI® SYNCHROFLEX Timing Belt

带宽 (单位: mm)
Belt width in mm

类型/节距
Typ/Pitch

带长 (单位: mm)
Belt length in mm

第三代规格
Specification Generation III

10 AT3/450 第三代

AT 型高性能同步带

AT high performance Timing Belts

AT 3

技术数据 Technical data

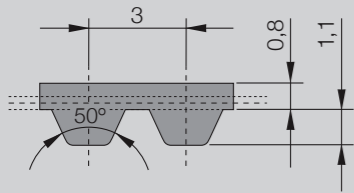

AT 3

CONTI® SYNCHROFLEX 同步带 (SFX) AT 3

公制节距和梯形齿的高性能 AT 齿型。

可用版本:

- 单面
- 增强设计
- 酰胺抗拉层
- 可按客户需求采用特殊聚氨酯材料
- 抗静电、着色、机械返工

FA: 背面较厚

FN: 皮带背面的齿型

CONTI® SYNCHROFLEX Timing Belt (SFX) AT 3

High performance AT profile with metric pitches and trapezoidal teeth.

Available versions:

- single-sided
- with reinforced design
- with Aramid tension member
- polyurethane special materials upon request
- antistatic, coloured, mechanical reworked

FA: with bigger back thickness

FN: with profiles on the back of the belt

类型 Type	/ 长度* / Length*	齿数 Number of teeth
AT 3 /	150	50
AT 3 /	201	67
AT 3 /	201 FN68	67
AT 3 /	252	84
AT 3 /	267	89
AT 3 /	270	90
AT 3 /	300	100
AT 3 /	351	117
AT 3 /	399	133
AT 3 /	417	139
AT 3 /	450	150
AT 3 /	486 FN18	162
AT 3 /	501	167
AT 3 /	549	183
AT 3 /	600	200
AT 3 /	639	213
AT 3 /	648	216
AT 3 /	648 FN24	216
AT 3 /	714	238
AT 3 /	816	272
AT 3 /	816 FA	272
AT 3 /	900	300
AT 3 /	1011	337

首选带宽* (单位: mm)

Preferred belt width* in mm:

6, 10, 16, 25, 32

* 可按客户要求提供其他尺寸。

* Other dimensions upon request.

1. 凸齿抗剪强度 (单位带齿强度)

Tooth shear strength (specific belt tooth strength)

每分钟转速 R.p.m. n [min ⁻¹]	F _{Uspez} F _{Uspec} [N/cm]	M _{spez} M _{spec} [Ncm/cm]	P _{spez} P _{spec} [W/cm]
0	32.34	1.544	0.000
20	32.00	1.528	0.032
40	31.68	1.513	0.063
60	31.37	1.498	0.094
80	31.08	1.484	0.124
100	30.80	1.471	0.154
150	30.16	1.440	0.226
200	29.58	1.412	0.296
300	28.55	1.363	0.428
400	27.68	1.322	0.554
500	26.91	1.285	0.673
600	26.23	1.252	0.787
700	25.62	1.223	0.897
730	25.45	1.215	0.929
800	25.07	1.197	1.003
900	24.56	1.173	1.105
1000	24.09	1.150	1.204
1100	23.65	1.129	1.301
1200	23.24	1.110	1.394
1300	22.86	1.091	1.486
1400	22.50	1.074	1.575
1460	22.29	1.064	1.627
1500	22.16	1.058	1.662
1600	21.84	1.043	1.747
1700	21.53	1.028	1.830
1800	21.24	1.014	1.911
1900	20.96	1.001	1.991
2000	20.70	0.988	2.070
2200	20.20	0.964	2.222
2400	19.73	0.942	2.367

每分钟转速 R.p.m. n [min ⁻¹]	F _{Uspez} F _{Uspec} [N/cm]	M _{spez} M _{spec} [Ncm/cm]	P _{spez} P _{spec} [W/cm]
2500	19.52	0.932	2.440
2600	19.31	0.922	2.510
2800	18.90	0.902	2.646
2880	18.75	0.895	2.700
3000	18.53	0.885	2.779
3200	18.17	0.868	2.907
3400	17.84	0.852	3.033
3600	17.52	0.837	3.153
3800	17.22	0.822	3.272
4000	16.93	0.808	3.386
4500	16.27	0.777	3.660
5000	15.67	0.748	3.917
5500	15.12	0.722	4.158
6000	14.62	0.698	4.386
6500	14.15	0.676	4.598
7000	13.72	0.655	4.802
7500	13.32	0.636	4.995
8000	12.94	0.618	5.176
8500	12.59	0.601	5.350
9000	12.25	0.585	5.512
9500	11.93	0.570	5.666
10000	11.63	0.555	5.815
12000	10.55	0.504	6.303
15000	9.22	0.440	6.914
18000	8.13	0.388	7.316
20000	7.50	0.358	7.499

转速超过每分钟20000转和/或带速超过80m/s时, 需要对传动装置进行特殊设计。请咨询我公司。

Rotational speeds over 20000 rpm and/or belt speeds over 80 m/s need special drive designs. Please ask our advice.

2. 抗拉层强度 (皮带允许张力 F_{zul})、带重

Tension member strength (permitted tensile force of the belt F_{zul}). Belt weight

带宽	Belt width	b	[mm]	6	10	16	25	32
抗拉层强度	Tension member strength	F _{zul}	[N]	190	380	646	1102	1406
带重	Belt weight	AT 3	[kg/m]	0.014	0.023	0.037	0.058	0.074

3. 挠性 (最低齿数、最小直径)

Flexibility (Minimum numbers of teeth, minimum diameter)

无反向弯曲 without contraflexure		同步带轮 Timing pulley	张紧轮 (光面), 在凸齿上运转 Tension roller (smooth), running on teeth	z _{min}	15	d _{min} [mm]	20
有反向弯曲 with contraflexure		同步带轮 Timing pulley	张紧轮 (光面), 在皮带背面运转 Tension roller (smooth), running on the back of the belt	z _{min}	20	d _{min} [mm]	20

订购实例 Order example

CONTI® SYNCHROFLEX 同步带
CONTI® SYNCHROFLEX Timing Belt

带宽 (单位: mm)
Belt width in mm

类型/节距
Typ/Pitch

带长 (单位: mm)
Belt length in mm

10 AT3/450

AT 型高性能同步带

AT high performance Timing Belts

AT 5 第三代 技术数据 Technical data

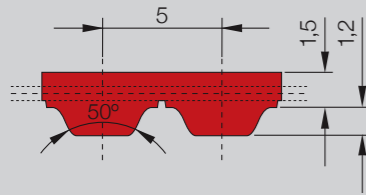

AT 5 Gen III

CONTI® SYNCHROFLEX 同步带 (SFX) AT 5 第三代

公制节距和梯形齿的高性能 AT 齿型。

标准版:

- 单面
- 红色高性能聚氨酯
- 高密度钢丝绳抗拉层
- 双线结构钢丝绳抗拉层
- 高挠性结构钢丝绳抗拉层

FA: 背面较厚

CONTI® SYNCHROFLEX Timing Belt (SFX) AT 5 GEN III

High performance AT profile with metric pitches and trapezoidal teeth.

Standard version:

- single-sided
- high performance polyurethane in red colour
- steel cord tension members with high density
- steel cord tension members in two-filament construction
- Steel cord tension members in highly flexible construction

FA: with bigger back thickness

订购实例 Order example

CONTI® SYNCHROFLEX 同步带 50 AT5/450 第三代
 CONTI® SYNCHROFLEX Timing Belt

带宽 (单位: mm) Belt width in mm _____

类型/节距 Typ/Pitch _____

带长 (单位: mm) Belt length in mm _____

第三代规格 Specification Generation III _____

类型 / 长度* Type / Length*	齿数 Number of teeth
AT 5 / 225	45
AT 5 / 255	51
AT 5 / 260	52
AT 5 / 280	56
AT 5 / 300	60
AT 5 / 330	66
AT 5 / 340	68
AT 5 / 375	75
AT 5 / 390	78
AT 5 / 420	84
AT 5 / 450	90
AT 5 / 455	91
AT 5 / 480	96
AT 5 / 490	98
AT 5 / 500	100
AT 5 / 525	105
AT 5 / 545	109
AT 5 / 600	120
AT 5 / 610	122
AT 5 / 620	124
AT 5 / 630	126
AT 5 / 660	132
AT 5 / 670	134
AT 5 / 690	138
AT 5 / 710	142
AT 5 / 720	144
AT 5 / 750	150
AT 5 / 780	156
AT 5 / 825	165
AT 5 / 860	172
AT 5 / 875	175
AT 5 / 900	180
AT 5 / 920	184
AT 5 / 975	195
AT 5 / 1050	210
AT 5 / 1125	225
AT 5 / 1230	246
AT 5 / 1500	300
AT 5 / 1750	350
AT 5 / 2000	400
AT 5 / 3350 FA	670
AT 5 / 3800 FA	760

首选带宽* (单位: mm):

Preferred belt width* in mm:

6, 10, 16, 25, 32, 50, 75, 100

* 可按客户要求提供其他尺寸。

* Other dimensions upon request.

1. 凸齿抗剪强度 (单位带齿强度)

Tooth shear strength (specific belt tooth strength)

每分钟转速 R.p.m. n [min ⁻¹]	F _{Uspez} F _{Uspec} [N/cm]	M _{spez} M _{spec} [Ncm/cm]	P _{spez} P _{spec} [W/cm]
0	44.13	3.51	0.00
20	43.63	3.48	0.07
40	43.13	3.44	0.14
60	42.63	3.40	0.21
80	42.25	3.36	0.28
100	41.88	3.33	0.35
200	40.00	3.19	0.67
300	38.63	3.08	0.96
400	37.25	2.96	1.24
500	36.25	2.88	1.51
600	35.25	2.80	1.76
700	34.28	2.74	2.00
800	33.50	2.68	2.24
900	32.88	2.61	2.46
1000	32.13	2.56	2.68
1100	31.50	2.51	2.89
1200	31.00	2.64	3.10
1300	30.38	2.42	3.30
1400	29.88	2.38	3.49
1500	29.38	2.34	3.68
1600	29.00	2.30	3.86
1700	28.50	2.27	4.04
1800	28.13	2.24	4.21
1900	27.75	2.21	4.39
2000	27.38	2.18	4.56
2200	26.63	2.12	4.89
2400	26.00	2.07	5.20
2600	25.38	2.02	5.50
2800	24.80	1.97	5.79
3000	24.28	1.93	6.06

每分钟转速 R.p.m. n [min ⁻¹]	F _{Uspez} F _{Uspec} [N/cm]	M _{spez} M _{spec} [Ncm/cm]	P _{spez} P _{spec} [W/cm]
3200	23.76	1.89	6.34
3400	23.30	1.85	6.60
3600	22.85	1.82	6.85
3800	22.41	1.78	7.10
4000	22.01	1.85	7.34
4500	21.08	1.68	7.90
5000	20.23	1.61	8.43
5500	19.45	1.55	8.91
6000	18.75	1.49	9.38
6500	18.10	1.44	9.80
7000	17.49	1.39	10.20
7500	16.93	1.35	10.58
8000	16.39	1.30	10.93
8500	15.89	1.26	11.25
9000	15.41	1.23	11.55
9500	14.96	1.19	11.84
10000	14.54	1.16	12.11

转速超过每分钟10000转和/或带速超过80m/s时, 需要对传动装置进行特殊设计。请咨询我公司。

Rotational speeds over 10000 rpm and/or belt speeds over 80 m/s need special drive designs. Please ask our advice.

2. 抗拉层强度 (皮带允许张力 F_{zul})、带重

Tension member strength (permitted tensile force of the belt F_{zul}). Belt weight

带宽	Belt width	b	[mm]	6	10	16	25	32	50	75	100
抗拉层强度	Tension member strength	F _{zul}	[N]	417	787	1342	2175	2823	4489	6803	9117
带重	Belt weight	AT 5 第三代	[kg/m]	0.022	0.036	0.058	0.090	0.115	0.180	0.270	0.360

3. 挠性 (最低齿数、最小直径)

Flexibility (Minimum numbers of teeth, minimum diameter)

无反向弯曲 without contraflexure		同步带轮 Timing pulley	Z _{min}	14
		张紧轮 (光面), 在凸齿轮上运转 Tension roller (smooth), running on teeth	d _{min} [mm]	20
有反向弯曲 with contraflexure		同步带轮 Timing pulley	Z _{min}	20
		张紧轮 (光面), 在皮带背面运转 Tension roller (smooth), running on the back of the belt	d _{min} [mm]	50

AT 型高性能同步带

AT high performance Timing Belts

AT 5

技术数据 Technical data

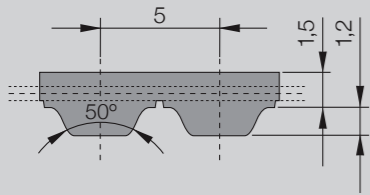

AT 5

CONTI® SYNCHROFLEX 同步带 (SFX) AT 5

公制节距和梯形齿的高性能 AT 齿型。
技术数据是指标准聚氨酯和标准钢丝绳抗拉层。

可用版本:

- 单面
- “E” 抗拉层, 挠性更好
- 增强设计
- 酰胺抗拉层
- 可按客户需求采用特殊聚氨酯材料
- 抗静电、着色、机械返工

FA: 背面较厚

CONTI® SYNCHROFLEX Timing Belt (SFX) AT 5

High performance AT profile with metric pitches and trapezoidal teeth.

The technical data refer to standard polyurethane and standard steel cord tension members.

Available versions:

- single-sided
- with “E” tension member for a better flexibility
- with reinforced design
- with Aramid tension member
- polyurethane special materials upon request
- antistatic, coloured, mechanical reworked

FA: with bigger back thickness

订购实例 Order example

CONTI® SYNCHROFLEX 同步带
CONTI® SYNCHROFLEX® Timing Belt

带宽 (单位: mm)
Belt width in mm 10 AT5/450

类型/节距
Typ/Pitch _____

带长 (单位: mm)
Belt length in mm _____

类型 Type	/ 长度* / Length*	齿数 Number of teeth
AT 5 /	225	45
AT 5 /	255	51
AT 5 /	260	52
AT 5 /	280	56
AT 5 /	300	60
AT 5 /	330	66
AT 5 /	340	68
AT 5 /	375	75
AT 5 /	390	78
AT 5 /	420	84
AT 5 /	450	90
AT 5 /	455	91
AT 5 /	480	96
AT 5 /	490	98
AT 5 /	500	100
AT 5 /	525	105
AT 5 /	545	109
AT 5 /	600	120
AT 5 /	610	122
AT 5 /	620	124
AT 5 /	630	126
AT 5 /	660	132
AT 5 /	670	134
AT 5 /	690	138
AT 5 /	710	142
AT 5 /	720	144
AT 5 /	750	150
AT 5 /	780	156
AT 5 /	825	165
AT 5 /	860	172
AT 5 /	875	175
AT 5 /	900	180
AT 5 /	920	184
AT 5 /	975	195
AT 5 /	1050	210
AT 5 /	1125	225
AT 5 /	1230	246
AT 5 /	1500	300
AT 5 /	1750	350
AT 5 /	2000	400
AT 5 /	3350 FA**	670
AT 5 /	3800 FA**	760

首选带宽* (单位: mm):
Preferred belt width* in mm:

10, 16, 25, 32, 50

* 可按客户要求提供其他尺寸。
** 请寻求康迪泰克传统系统有限公司的技术支持。
* Other dimensions upon request.
** Please request technical support from the ContiTech Antriebssysteme GmbH.

1. 凸齿抗剪强度 (单位带齿强度)

Tooth shear strength (specific belt tooth strength)

每分钟转速 R.p.m. n [min ⁻¹]	F _{Uspez} F _{Uspec} [N/cm]	M _{spez} M _{spec} [Ncm/cm]	P _{spez} P _{spec} [W/cm]
0	35.3	2.810	0.000
20	34.9	2.780	0.058
40	34.5	2.750	0.115
60	34.1	2.720	0.171
80	33.8	2.690	0.225
100	33.5	2.660	0.279
200	32.0	2.550	0.534
300	30.9	2.460	0.771
400	29.8	2.370	0.995
500	29.0	2.300	1.207
600	28.2	2.240	1.409
700	27.5	2.190	1.603
800	26.8	2.140	1.789
900	26.3	2.090	1.969
1000	25.7	2.050	2.140
1100	25.2	2.010	2.310
1200	24.8	1.970	2.480
1300	24.3	1.936	2.640
1400	23.9	1.903	2.790
1500	23.5	1.872	2.940
1600	23.2	1.843	3.090
1700	22.8	1.816	3.230
1800	22.5	1.789	3.370
1900	22.2	1.764	3.510
2000	21.9	1.740	3.650
2200	21.3	1.695	3.910
2400	20.8	1.654	4.160
2600	20.3	1.615	4.400
2800	19.84	1.579	4.630
3000	19.42	1.545	4.850

每分钟转速 R.p.m. n [min ⁻¹]	F _{Uspez} F _{Uspec} [N/cm]	M _{spez} M _{spec} [Ncm/cm]	P _{spez} P _{spec} [W/cm]
3200	19.01	1.513	5.07
3400	18.64	1.483	5.28
3600	18.28	1.454	5.48
3800	17.93	1.427	5.68
4000	17.61	1.401	5.87
4500	16.86	1.342	6.32
5000	16.18	1.288	6.74
5500	15.56	1.239	7.13
6000	15.00	1.194	7.50
6500	14.48	1.152	7.84
7000	13.99	1.113	8.16
7500	13.54	1.077	8.46
8000	13.11	1.043	8.74
8500	12.71	1.011	9.00
9000	12.33	0.981	9.24
9500	11.97	0.953	9.47
10000	11.63	0.925	9.69

转速超过每分钟10000转和/或带速超过80m/s⁹¹ 需要对传动装置进行特殊设计。请咨询我公司。

Rotational speeds over 10000 rpm and/or belt speeds over 80 m/s need special drive designs. Please ask our advice.

2. 抗拉层强度 (皮带允许张力 F_{zul})、带重

Tension member strength (permitted tensile force of the belt F_{zul}). Belt weight

带宽 Belt width	b	[mm]	6	10	16	25	32	50	75	100
抗拉层强度 Tension member strength	F _{zul}	[N]	350	700	1260	2030	2660	4200	6370	8610
带重 Belt weight	AT 5	[kg/m]	0.020	0.034	0.054	0.085	0.109	0.170	0.255	0.340

3. 挠性 (最低齿数、最小直径)

Flexibility (Minimum numbers of teeth, minimum diameter)

无反向弯曲 without contraflexure		同步带轮 Timing pulley	Z _{min}	15
		张紧轮 (光面), 在凸齿轮上运转 Tension roller (smooth), running on teeth	d _{min} [mm]	25
有反向弯曲 with contraflexure		同步带轮 Timing pulley	Z _{min}	20
		张紧轮 (光面), 在皮带背面运转 Tension roller (smooth), running on the back of the belt	d _{min} [mm]	60

AT 型高性能同步带

AT high performance Timing Belts

AT 10 第三代

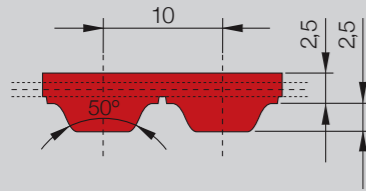

AT 10 Gen III

CONTI® SYNCHROFLEX 同步带 (SFX) AT 10 第三代

公制节距和梯形齿的高性能 AT 齿型。

标准版:

- 单面
- 红色高性能聚氨酯
- 高密度钢丝绳抗拉层
- 双线结构钢丝绳抗拉层

FN: 皮带背面的齿型

CONTI® SYNCHROFLEX Timing Belt (SFX) AT 10 GEN III

High performance AT profile with metric pitches and trapezoidal teeth.

Standard version:

- single-sided
- high performance polyurethane in red colour
- steel cord tension members with high density
- steel cord tension members in two-filament construction

FN: with profiles on the back of the belt

订购实例 Order example

CONTI® SYNCHROFLEX 同步带
CONTI® SYNCHROFLEX Timing Belt

带宽 (单位: mm)
Belt width in mm 32 AT10/800

类型/节距
Typ/Pitch 第三代

带长 (单位: mm)
Belt length in mm _____

第三代规格
Specification Generation III _____

类型 / 长度* Type / Length*	齿数 Number of teeth
AT 10 / 440	44
AT 10 / 460	46
AT 10 / 500	50
AT 10 / 560	56
AT 10 / 570	57
AT 10 / 580	58
AT 10 / 600	60
AT 10 / 610	61
AT 10 / 660	66
AT 10 / 700	70
AT 10 / 730	73
AT 10 / 780	78
AT 10 / 800	80
AT 10 / 840	84
AT 10 / 840 FN2	84
AT 10 / 880	88
AT 10 / 890	89
AT 10 / 920	92
AT 10 / 960	96
AT 10 / 980	98
AT 10 / 1000	100
AT 10 / 1010	101
AT 10 / 1050	105
AT 10 / 1080	108
AT 10 / 1100	110
AT 10 / 1150	115
AT 10 / 1200	120
AT 10 / 1210	121
AT 10 / 1250	125
AT 10 / 1280	128
AT 10 / 1300	130
AT 10 / 1320	132
AT 10 / 1350	135
AT 10 / 1360	136
AT 10 / 1360 FN2	136
AT 10 / 1400	140
AT 10 / 1480	148
AT 10 / 1500	150
AT 10 / 1600	160
AT 10 / 1700	170
AT 10 / 1720	172
AT 10 / 1800	180
AT 10 / 1860	186
AT 10 / 1940	194

首选带宽* (单位: mm):
Preferred belt width* in mm:
16, 25, 32, 50, 75, 100, 150

* 可按客户要求提供其他尺寸。
* Other dimensions upon request.

技术数据 Technical data

1. 凸齿抗剪强度 (单位带齿强度)

Tooth shear strength (specific belt tooth strength)

每分钟转速 R.p.m. n [min ⁻¹]	F _{Uspez} F _{Uspec} [N/cm]	M _{spez} M _{spec} [Ncm/cm]	P _{spez} P _{spec} [W/cm]
0	91.88	14.63	0.00
20	90.50	14.41	0.30
40	89.25	14.21	0.60
60	88.13	14.01	0.88
80	87.00	13.84	1.16
100	85.88	13.68	1.43
200	81.25	12.94	2.71
300	77.63	12.35	3.88
400	74.38	11.85	4.96
500	71.75	11.41	5.98
600	69.38	11.04	6.94
700	67.13	10.69	7.84
800	65.25	10.39	8.70
900	63.50	10.10	9.53
1000	61.88	9.85	10.31
1100	60.38	9.61	11.08
1200	59.00	9.39	11.80
1300	57.75	9.19	12.50
1400	56.50	8.99	13.18
1500	55.38	8.80	13.84
1600	54.25	8.64	14.46
1700	53.25	8.48	15.08
1800	52.25	8.31	15.68
1900	51.25	8.16	16.25
2000	50.38	8.03	16.80
2200	48.75	7.75	17.88
2400	47.25	7.51	18.88
2600	45.75	7.29	19.83
2800	44.38	7.08	20.73
3000	43.13	6.88	21.59

每分钟转速 R.p.m. n [min ⁻¹]	F _{Uspez} F _{Uspec} [N/cm]	M _{spez} M _{spec} [Ncm/cm]	P _{spez} P _{spec} [W/cm]
3200	42.00	6.69	22.40
3400	40.88	6.50	23.16
3600	39.88	6.34	23.89
3800	38.88	6.18	24.59
4000	37.88	6.03	25.25
4500	35.63	5.68	26.75
5000	33.63	5.36	28.13
5500	31.88	5.08	29.25
6000	30.25	4.81	30.25
6500	28.75	4.56	31.13
7000	27.25	4.34	31.88
7500	26.00	4.13	32.50
8000	24.71	3.94	33.00
8500	23.55	3.75	33.38
9000	22.44	3.58	33.63
9500	21.40	3.40	33.88
10000	20.40	3.25	34.00

转速超过每分钟10000转和/或带速超过60m/s时, 需要对传动装置进行特殊的设计。请咨询我公司。

Rotational speeds over 10000 rpm and/or belt speeds over 60 m/s need special drive designs. Please ask our advice.

2. 抗拉层强度 (皮带允许张力 F_{zul})、带重

Tension member strength (permitted tensile force of the belt F_{zul}). Belt weight

带宽	Belt width	b	[mm]	16	25	32	50	75	100	150
抗拉层强度	Tension member strength	F _{zul}	[N]	3000	5000	6750	10750	16500	22000	33500
带重	Belt weight	AT 10 第三代	[kg/m]	0.117	0.183	0.234	0.365	0.548	0.730	1.095

3. 挠性 (最低齿数、最小直径)

Flexibility (Minimum numbers of teeth, minimum diameter)

无反向弯曲 without contraflexure		同步带轮 Timing pulley	Z _{min}	15
		张紧轮 (光面), 在凸齿轮上运转 Tension roller (smooth), running on teeth	d _{min} [mm]	50
有反向弯曲 with contraflexure		同步带轮 Timing pulley	Z _{min}	25
		张紧轮 (光面), 在皮带背面运转 Tension roller (smooth), running on the back of the belt	d _{min} [mm]	100

AT 型高性能同步带

AT high performance Timing Belts

AT 10 技术数据 Technical data

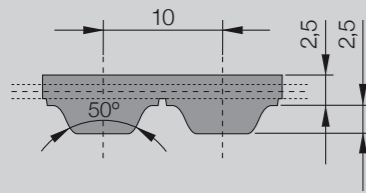

AT 10

CONTI® SYNCHROFLEX 同步带 (SFX) AT 10

公制节距和梯形齿的高性能 AT 齿型。
技术数据是指标准聚氨酯和标准钢丝绳抗拉层。

可用版本:

- 单面
- “E” 抗拉层, 挠性更好
- 增强设计
- 芳纶抗拉层
- 可按客户需求采用特殊聚氨酯材料
- 抗静电、着色、机械返工

FN: 皮带背面的齿型

CONTI® SYNCHROFLEX Timing Belt (SFX) AT 10

High performance AT profile with metric pitches and trapezoidal teeth.

The technical data refer to standard polyurethane and standard steel cord tension members.

Available versions:

- single-sided
- with “E” tension member for a better flexibility
- with reinforced design
- with Aramid tension member
- polyurethane special materials upon request
- antistatic, coloured, mechanical reworked

FN: with profiles on the back of the belt

订购实例 Order example

CONTI® SYNCHROFLEX 同步带
CONTI® SYNCHROFLEX Timing Belt

带宽 (单位: mm)
Belt width in mm 32 AT10/800

类型/节距
Typ/Pitch _____

带长 (单位: mm)
Belt length in mm _____

类型 Type	/ 长度* / Length*	齿数 Number of teeth
AT 10 /	440	44
AT 10 /	460	46
AT 10 /	500	50
AT 10 /	560	56
AT 10 /	570	57
AT 10 /	580	58
AT 10 /	600	60
AT 10 /	610	61
AT 10 /	660	66
AT 10 /	700	70
AT 10 /	730	73
AT 10 /	780	78
AT 10 /	800	80
AT 10 /	840	84
AT 10 /	840 FN2	84
AT 10 /	880	88
AT 10 /	890	89
AT 10 /	920	92
AT 10 /	960	96
AT 10 /	980	98
AT 10 /	1000	100
AT 10 /	1010	101
AT 10 /	1050	105
AT 10 /	1080	108
AT 10 /	1100	110
AT 10 /	1150	115
AT 10 /	1200	120
AT 10 /	1210	121
AT 10 /	1250	125
AT 10 /	1280	128
AT 10 /	1300	130
AT 10 /	1320	132
AT 10 /	1350	135
AT 10 /	1360	136
AT 10 /	1360 FN2	136
AT 10 /	1400	140
AT 10 /	1480	148
AT 10 /	1500	150
AT 10 /	1600	160
AT 10 /	1700	170
AT 10 /	1720	172
AT 10 /	1800	180
AT 10 /	1860	186
AT 10 /	1940	194

首选带宽* (单位: mm):
Preferred belt width* in mm:

16, 25, 32, 50, 75, 100

* 可按客户要求提供其他尺寸。
* Other dimensions upon request.

1. 凸齿抗剪强度 (单位带齿强度)

Tooth shear strength (specific belt tooth strength)

每分钟转速 R.p.m. n [min ⁻¹]	F _{Uspez} F _{Uspec} [N/cm]	M _{spez} M _{spec} [Ncm/cm]	P _{spez} P _{spec} [W/cm]
0	73.5	11.70	0.000
20	72.4	11.53	0.241
40	71.4	11.37	0.476
60	70.5	11.21	0.705
80	69.6	11.07	0.928
100	68.7	10.94	1.145
200	65.0	10.35	2.170
300	62.1	9.88	3.100
400	59.5	9.48	3.970
500	57.4	9.13	4.780
600	55.5	8.83	5.550
700	53.7	8.55	6.270
800	52.2	8.31	6.960
900	50.8	8.08	7.620
1000	49.5	7.88	8.250
1100	48.3	7.69	8.860
1200	47.2	7.51	9.440
1300	46.2	7.35	10.000
1400	45.2	7.19	10.540
1500	44.3	7.04	11.070
1600	43.4	6.91	11.570
1700	42.6	6.78	12.060
1800	41.8	6.65	12.540
1900	41.0	6.53	13.000
2000	40.3	6.42	13.440
2200	39.0	6.20	14.300
2400	37.8	6.01	15.100
2600	36.6	5.83	15.860
2800	35.5	5.66	16.580
3000	34.5	5.50	17.270

每分钟转速 R.p.m. n [min ⁻¹]	F _{Uspez} F _{Uspec} [N/cm]	M _{spez} M _{spec} [Ncm/cm]	P _{spez} P _{spec} [W/cm]
3200	33.60	5.35	17.92
3400	32.70	5.20	18.53
3600	31.90	5.07	19.11
3800	31.10	4.94	19.67
4000	30.30	4.82	20.20
4500	28.50	4.54	21.40
5000	26.90	4.29	22.50
5500	25.50	4.06	23.40
6000	24.20	3.85	24.20
6500	23.00	3.65	24.90
7000	21.80	3.47	25.50
7500	20.80	3.30	26.00
8000	19.77	3.15	26.40
8500	18.84	3.00	26.70
9000	17.95	2.86	26.90
9500	17.12	2.72	27.10
10000	16.32	2.60	27.20

转速超过每分钟10000转和/或带速超过60m/s时, 需要对传动装置进行特殊的设计。请咨询我公司。

Rotational speeds over 10000 rpm and/or belt speeds over 60 m/s need special drive designs. Please ask our advice.

2. 抗拉层强度 (皮带允许张力 F_{zul})、带重

Tension member strength (permitted tensile force of the belt F_{zul}). Belt weight

带宽	Belt width	b	[mm]	16	25	32	50	75	100	150
抗拉层强度	Tension member strength	F _{zul}	[N]	2000	3500	4750	7750	12000	16000	24500
带重	Belt weight	AT 10	[kg/m]	0.101	0.158	0.202	0.315	0.473	0.630	0.945

3. 挠性 (最低齿数、最小直径)

Flexibility (Minimum numbers of teeth, minimum diameter)

无反向弯曲 without contraflexure		同步带轮 Timing pulley	Z _{min}	15
		张紧轮 (光面), 在凸齿轮上运转 Tension roller (smooth), running on teeth	d _{min} [mm]	50
有反向弯曲 with contraflexure		同步带轮 Timing pulley	Z _{min}	25
		张紧轮 (光面), 在皮带背面运转 Tension roller (smooth), running on the back of the belt	d _{min} [mm]	120

AT 型高性能同步带

AT high performance Timing Belts

AT 20 第三代

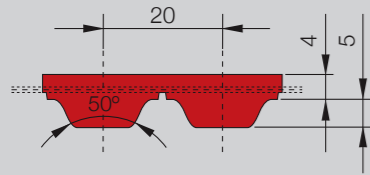

AT 20 Gen III

CONTI® SYNCHROFLEX 同步带 (SFX) AT 20 第三代

公制节距和梯形齿的高性能 AT 齿型。

标准版:

- 单面
- 红色高性能聚氨酯
- 高密度钢丝绳抗拉层
- 双线结构钢丝绳抗拉层

FN: 皮带背面的齿型

CONTI® SYNCHROFLEX Timing Belt (SFX) AT 20 GEN III

High performance AT profile with metric pitches and trapezoidal teeth.

Standard version:

- single-sided
- high performance polyurethane in red colour
- steel cord tension members with high density
- steel cord tension members in two-filament construction

FN: with profiles on the back of the belt

类型 / 长度* Type / Length*	齿数 Number of teeth
AT 20 / 1000**	50
AT 20 / 1100	55
AT 20 / 1200**	60
AT 20 / 1260	63
AT 20 / 1500**	75
AT 20 / 1600**	80
AT 20 / 1700	85
AT 20 / 1760**	88
AT 20 / 1800	90
AT 20 / 1900**	95
AT 20 / 1960**	98

首选带宽* (单位: mm):

Preferred belt width* in mm:

32, 50, 75, 100

- * 可按客户要求提供其他尺寸。
- ** 要减小带轮的中心距, 请寻求销售合作伙伴的技术支持。
- * Other dimensions upon request.
- ** In combination with reduced pulley gap please ask for technical support from your sales partner.

技术数据 Technical data

1. 凸齿抗剪强度 (单位带齿强度)

Tooth shear strength (specific belt tooth strength)

每分钟转速 R.p.m. n [min ⁻¹]	F _{Uspez} F _{Uspec} [N/cm]	M _{spez} M _{spec} [Ncm/cm]	P _{spez} P _{spec} [W/cm]
0	183.750	58.489	0.000
20	180.310	57.395	1.202
40	177.108	56.375	2.361
60	174.112	55.422	3.482
80	171.298	54.526	4.568
100	168.645	53.682	5.622
150	162.609	51.760	8.130
200	157.268	50.060	10.485
300	148.138	47.154	14.814
400	140.512	44.726	18.735
500	133.963	42.642	22.327
600	128.226	40.816	25.645
700	123.120	39.190	28.728
800	118.521	37.726	31.606
900	114.336	36.394	34.301
1000	110.498	35.173	36.833
1100	106.953	34.044	39.216
1200	103.66	32.996	41.464
1300	100.585	32.017	43.587
1400	97.701	31.099	45.594
1500	94.986	30.235	47.493
1600	92.421	29.419	49.291
1700	89.990	28.645	50.995
1800	87.681	27.910	52.608
1900	85.481	27.209	54.138
2000	83.38	26.541	55.587
2200	79.444	25.288	58.259
2400	75.816	24.133	60.653
2600	72.451	23.062	62.791
2800	69.314	22.063	64.693

每分钟转速 R.p.m. n [min ⁻¹]	F _{Uspez} F _{Uspec} [N/cm]	M _{spez} M _{spec} [Ncm/cm]	P _{spez} P _{spec} [W/cm]
3000	66.375	21.128	66.375
3200	63.612	20.248	67.852
3400	61.003	19.418	69.137
3600	58.534	18.632	70.241
3800	56.189	17.886	71.173
4000	53.957	17.175	71.943
4500	48.806	15.535	73.209
5000	44.170	14.060	73.617
5500	39.955	12.718	73.251
6000	36.091	11.488	72.183
6500	32.525	10.353	70.470

转速超过每分钟6500转和/或带速超过40m/s时, 需要对传动装置进行特殊设计。请咨询我公司。

Rotational speeds over 6500 rpm and/or belt speeds over 40 m/s need special drive designs. Please ask our advice.

2. 抗拉层强度 (皮带允许张力 F_{zul})、带重

Tension member strength (permitted tensile force of the belt F_{zul}). Belt weight

带宽	Belt width	b	[mm]	25	32	50	75	100	150
抗拉层强度	Tension member strength	F _{zul}	[N]	6300	8550	13950	21600	28800	44100
带重	Belt weight	AT 20 第三代	[kg/m]	0.290	0.371	0.583	0.87	1.16	1.74

3. 挠性 (最低齿数、最小直径)

Flexibility (Minimum numbers of teeth, minimum diameter)

无反向弯曲 without contraflexure		同步带轮 Timing pulley	Z _{min}	18
		张紧轮 (光面), 在凸齿轮上运转 Tension roller (smooth), running on teeth	d _{min} [mm]	120
有反向弯曲 with contraflexure		同步带轮 Timing pulley	Z _{min}	25
		张紧轮 (光面), 在皮带背面运转 Tension roller (smooth), running on the back of the belt	d _{min} [mm]	180

订购实例 Order example

CONTI® SYNCHROFLEX 同步带 32 AT20/1000 第三代
CONTI® SYNCHROFLEX Timing Belt

带宽 (单位: mm)
Belt width in mm _____

类型/节距
Typ/Pitch _____

带长 (单位: mm)
Belt length in mm _____

第三代规格
Specification Generation III _____

AT 型高性能同步带

AT high performance Timing Belts

AT 20

技术数据 Technical data

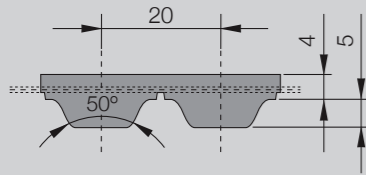

AT 20

CONTI® SYNCHROFLEX 同步带 (SFX) AT 20

公制节距和梯形齿的高性能 AT 齿型。
技术数据是指标准聚氨酯和标准钢丝绳抗拉层。

可用版本:

- 单面
- 可按客户需求采用特殊聚氨酯材料
- 抗静电、着色、机械返工

CONTI® SYNCHROFLEX Timing Belt (SFX) AT 20

High performance AT profile with metric pitches and trapezoidal teeth.

The technical data refer to standard polyurethane and standard steel cord tension members.

Available versions:

- single-sided
- polyurethane special materials upon request
- antistatic, coloured, mechanical reworked

类型 Type	/ 长度* / Length*	齿数 Number of teeth
AT 20 /	1000**	50
AT 20 /	1100	55
AT 20 /	1200**	60
AT 20 /	1260	63
AT 20 /	1500**	75
AT 20 /	1600**	80
AT 20 /	1700	85
AT 20 /	1760**	88
AT 20 /	1800	90
AT 20 /	1900**	95
AT 20 /	1960**	98

首选带宽* (单位: mm):

Preferred belt width* in mm:

32, 50, 75, 100

* 可按客户要求提供其他尺寸。

** 要减小带轮的中心距, 请寻求销售合作伙伴的技术支持。

* Other dimensions upon request.

** In combination with reduced pulley gap please ask for technical support from your sales partner.

1. 凸齿抗剪强度 (单位带齿强度)

Tooth shear strength (specific belt tooth strength)

每分钟转速 R.p.m. n [min ⁻¹]	F _{Uspez} F _{Uspec} [N/cm]	M _{spez} M _{spec} [Ncm/cm]	P _{spez} P _{spec} [W/cm]
0	147.0	46.80	0.000
20	144.2	45.90	0.962
40	141.7	45.10	1.889
60	139.3	44.30	2.790
80	137.0	43.60	3.650
100	134.9	42.90	4.500
200	125.8	40.00	8.390
300	118.5	37.70	11.850
400	112.4	35.80	14.990
500	107.2	34.10	17.860
600	102.6	32.70	20.500
700	98.5	31.40	23.000
800	94.8	30.20	25.300
900	91.5	29.10	27.400
1000	88.4	28.10	29.500
1100	85.6	27.20	31.400
1200	82.9	26.40	33.200
1300	80.5	25.60	34.900
1400	78.2	24.90	36.500
1500	76.0	24.20	38.000
1600	73.9	23.50	39.400
1700	72.0	22.90	40.800
1800	70.1	22.30	42.100
1900	68.4	21.80	43.300
2000	66.7	21.20	44.500
2200	63.6	20.20	46.600
2400	60.7	19.31	48.500
2600	58.0	18.45	50.200
2800	55.5	17.65	51.800
3000	53.1	16.90	53.100

每分钟转速 R.p.m. n [min ⁻¹]	F _{Uspez} F _{Uspec} [N/cm]	M _{spez} M _{spec} [Ncm/cm]	P _{spez} P _{spec} [W/cm]
3200	50.9	16.20	54.300
3400	48.8	15.53	55.300
3600	46.8	14.91	56.200
3800	45.0	14.31	56.900
4000	43.2	13.74	57.600
4500	39.0	12.43	58.600
5000	35.3	11.25	58.800
5500	32.0	10.17	60.600
6000	28.9	9.19	61.700
6500	26.0	8.28	62.400

转速超过每分钟6500转和/或带速超过40m/s时, 需要对传动装置进行特殊设计。请咨询我公司。

Rotational speeds over 6500 rpm and/or belt speeds over 40 m/s need special drive designs. Please ask our advice.

2. 抗拉层强度 (皮带允许张力 F_{zul})、带重

Tension member strength (permitted tensile force of the belt F_{zul}). Belt weight

带宽 Belt width	b	[mm]	32	50	75	100	150
抗拉层强度 Tension member strength	F _{zul}	[N]	6750	11250	17550	23850	36450
带重 Belt weight	AT 20	[kg/m]	0.339	0.530	0.795	1.060	1.590

3. 挠性 (最低齿数、最小直径)

Flexibility (Minimum numbers of teeth, minimum diameter)

无反向弯曲 without contraflexure		同步带轮 Timing pulley	z _{min}	18
		张紧轮 (光面), 在凸齿轮上运转 Tension roller (smooth), running on teeth	d _{min} [mm]	120
有反向弯曲 with contraflexure		同步带轮 Timing pulley	z _{min}	25
		张紧轮 (光面), 在皮带背面运转 Tension roller (smooth), running on the back of the belt	d _{min} [mm]	180

订购实例 Order example

CONTI® SYNCHROFLEX 同步带
CONTI® SYNCHROFLEX Timing Belt

带宽 (单位: mm)
Belt width in mm

类型/节距
Typ/Pitch

带长 (单位: mm)
Belt length in mm

50 AT20/1500

T 型同步带

T standard Timing Belts

T 2

技术数据 Technical data

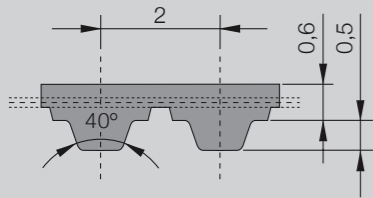

T 2

CONTI® SYNCHROFLEX 同步带 (SFX) T 2

公制节距和梯形齿标准 T 型齿型。
技术数据是指标准聚氨酯和标准钢丝绳抗拉层。

可用版本:

- 单面
- 酰胺抗拉层
- 可按客户需求采用特殊聚氨酯材料
- 抗静电、着色、机械返工

FA: 背面较厚

FN: 皮带背面的齿型

CONTI® SYNCHROFLEX Timing Belt (SFX) T 2

Standard T profile with metric pitch and trapezoidal teeth.

The technical data refer to standard polyurethane and standard steel cord tension members.

Available versions:

- single-sided
- with Aramid tension member
- polyurethane special materials upon request
- antistatic, coloured, mechanical reworked

FA: with bigger back thickness

FN: with profiles on the back of the belt

类型 Type	/ 长度* / Length*	齿数 Number of teeth
T 2 / 68		34
T 2 / 90		45
T 2 / 108		54
T 2 / 118		59
T 2 / 120		60
T 2 / 120 FA		60
T 2 / 138		69
T 2 / 140		70
T 2 / 144		72
T 2 / 150		75
T 2 / 160		80
T 2 / 180		90
T 2 / 200		100
T 2 / 220		110
T 2 / 220 FA		110
T 2 / 220 FN2		110
T 2 / 240		120
T 2 / 256		128
T 2 / 262		131
T 2 / 280		140
T 2 / 292		146
T 2 / 320		160
T 2 / 360		180
T 2 / 600		300
T 2 / 710		355
T 2 / 710 FA		355
T 2 / 1296 FA		648

首选带宽* (单位: mm):

Preferred belt width* in mm:

4, 6, 10

* 可按客户要求提供其他尺寸。

* Other dimensions upon request.

1. 凸齿抗剪强度 (单位带齿强度)

Tooth shear strength (specific belt tooth strength)

每分钟转速 R.p.m. n [min ⁻¹]	F _{Uspez} F _{Uspec} [N/cm]	M _{spez} M _{spec} [Ncm/cm]	P _{spez} P _{spec} [W/cm]
0	6.58	0.209	0.000
20	6.36	0.202	0.004
40	6.18	0.197	0.008
60	6.03	0.192	0.012
80	5.90	0.188	0.016
100	5.79	0.184	0.019
150	5.56	0.177	0.028
200	5.38	0.171	0.036
300	5.10	0.162	0.051
400	4.89	0.156	0.065
500	4.72	0.150	0.079
600	4.58	0.146	0.092
700	4.45	0.142	0.104
730	4.42	0.141	0.108
800	4.35	0.138	0.116
900	4.25	0.135	0.127
1000	4.16	0.132	0.139
1100	4.08	0.130	0.150
1200	4.01	0.128	0.160
1300	3.94	0.125	0.171
1400	3.88	0.124	0.181
1460	3.85	0.123	0.187
1500	3.82	0.122	0.191
1600	3.77	0.120	0.201
1700	3.72	0.118	0.211
1800	3.67	0.117	0.220
1900	3.62	0.115	0.229
2000	3.58	0.114	0.239
2200	3.50	0.111	0.257
2400	3.42	0.109	0.274

每分钟转速 R.p.m. n [min ⁻¹]	F _{Uspez} F _{Uspec} [N/cm]	M _{spez} M _{spec} [Ncm/cm]	P _{spez} P _{spec} [W/cm]
2500	3.39	0.108	0.282
2600	3.35	0.107	0.290
2800	3.29	0.105	0.307
2880	3.26	0.104	0.313
3000	3.23	0.103	0.323
3200	3.17	0.101	0.338
3400	3.12	0.099	0.354
3600	3.07	0.098	0.368
3800	3.02	0.096	0.383
4000	2.98	0.095	0.397
4500	2.88	0.092	0.432
5000	2.78	0.088	0.463
5500	2.70	0.086	0.495
6000	2.63	0.084	0.526
6500	2.56	0.081	0.555
7000	2.49	0.079	0.581
7500	2.43	0.077	0.607
8000	2.37	0.075	0.632
8500	2.32	0.074	0.657
9000	2.27	0.072	0.681
9500	2.22	0.071	0.703
10000	2.18	0.069	0.727
12000	2.02	0.064	0.808
15000	1.82	0.058	0.910
18000	1.66	0.053	0.996
20000	1.57	0.050	1.047

转速超过每分钟20000转和/或带速超过80m/s时, 需要对传动装置进行特殊设计。请咨询我公司。

Rotational speeds over 20000 rpm and/or belt speeds over 80 m/s need special drive designs. Please ask our advice.

2. 抗拉层强度 (皮带允许张力 F_{zul})、带重

Tension member strength (permitted tensile force of the belt F_{zul}). Belt weight

带宽 Belt width	b	[mm]	4	6	10	16	25	32
抗拉层强度 Tension member strength	F _{zul}	[N]	39	65	117	195	312	403
带重 Belt weight	T 2	[kg/m]	0.004	0.007	0.011	0.018	0.028	0.035

3. 挠性 (最低齿数、最小直径)

Flexibility (Minimum numbers of teeth, minimum diameter)

无反向弯曲 without contraflexure		同步带轮 Timing pulley	z _{min}	10
		张紧轮 (光面), 在凸齿轮上运转 Tension roller (smooth), running on teeth	d _{min} [mm]	15
有反向弯曲 with contraflexure		同步带轮 Timing pulley	z _{min}	18
		张紧轮 (光面), 在皮带背面运转 Tension roller (smooth), running on the back of the belt	d _{min} [mm]	15

订购实例 Order example

CONTI® SYNCHROFLEX 同步带
CONTI® SYNCHROFLEX Timing Belt
带宽 (单位: mm)
Belt width in mm 6 T2/240
类型/节距
Typ/Pitch _____
带长 (单位: mm)
Belt length in mm _____

T 型同步带

T 2.5/T 2.5-DL

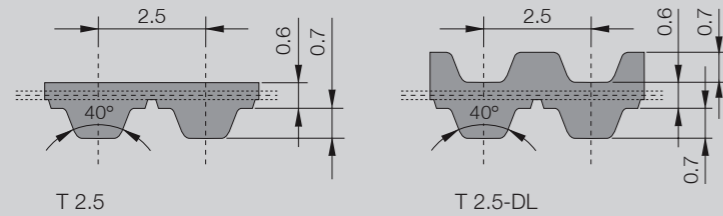

CONTI® SYNCHROFLEX 同步带 (SFX) T 2.5/T 2.5-DL

按照 DIN 7721 确定的公制节距和梯形齿的标准 T 齿型。

技术数据是指标准聚氨酯和标准钢丝绳抗拉层。

可用版本:

- 单面 (als Standard)
- 酰胺抗拉层
- 可按客户需求采用特殊聚氨酯材料
- 防静电、着色、机械返工

DL: 双面

FA: 背面较厚

FN: 皮带背面的齿型

CONTI® SYNCHROFLEX Timing Belt (SFX) T 2.5/T 2.5-DL

Standard T profile according to DIN 7721 with metric pitch and trapezoidal teeth.

The technical data refer to standard polyurethane and standard steel cord tension members.

Available versions:

- single-sided (as standard)
- with Aramid tension member
- polyurethane special materials upon request
- antistatic, coloured, mechanical reworked

DL: double-sided

FA: with bigger back thickness

FN: with profiles on the back of the belt

订购实例 Order example

CONTI® SYNCHROFLEX 同步带
CONTI® SYNCHROFLEX® Timing Belt
带宽 (单位: mm)
Belt width in mm 10 T2,5/380
类型/节距
Typ/Pitch _____
带长 (单位: mm)
Belt length in mm _____

首选带宽*
Preferred belt width*

in mm: 4, 6, 10

* 可按客户需求提供其他尺寸

* Other dimensions upon request.

类型 / 长度* Type / Length*	齿数 Number of teeth
T 2.5 55 FA	22
T 2.5 / 75 FN2	30
T 2.5 / 120	48
T 2.5 / 145	58
T 2.5 / 160	64
T 2.5 / 160 FA	64
T 2.5 / 177.5	71
T 2.5 / 180	72
T 2.5 / 182.5	73
T 2.5 / 200	80
T 2.5 / 210 FA	84
T 2.5 / 210 FN 28	84
T 2.5 / 220 FN 3	88
T 2.5 / 225	90
T 2.5 / 230	92
T 2.5 / 230 FA	92
T 2.5 / 245	98
T 2.5 / 250	100
T 2.5 / 265	106
T 2.5 / 285	114
T 2.5 / 285 FA	114
T 2.5 / 290	116
T 2.5 / 305	122
T 2.5 / 305 FA	122
T 2.5 / 305 FN1	122
T 2.5 / 317.5	127
T 2.5 317.5 DL	127
T 2.5 / 330	132
T 2.5 / 380	152
T 2.5 / 395	158
T 2.5 / 400 FA	160
T 2.5 / 415 DL	166
T 2.5 / 420	168
T 2.5 / 420 FN 168	168
T 2.5 / 457.5 DL	183
T 2.5 / 480	192
T 2.5 / 480 FA	192
T 2.5 / 480 FN	192
T 2.5 / 500	200
T 2.5 / 500 FA	200
T 2.5 / 540	216
T 2.5 / 540 FA	216
T 2.5 / 600	240
T 2.5 / 600 FA	240
T 2.5 / 620	248
T 2.5 / 650	260
T 2.5 / 650 FN2	260
T 2.5 / 780	312
T 2.5 / 780 FA	312
T 2.5 / 950	380
T 2.5 / 1300	520
T 2.5 / 1300 FA	520
T 2.5 / 1350 FA	540
T 2.5 / 1475 FA	590

T standard Timing Belts

技术数据 Technical data

1. 凸齿抗剪强度 (单位带齿强度)

Tooth shear strength (specific belt tooth strength)

每分钟转速 R.p.m. n [min ⁻¹]	F _{Uspez} F _{Uspec} [N/cm]	M _{spez} M _{spec} [Ncm/cm]	P _{spez} P _{spec} [W/cm]
0	9.03	0.359	0.000
20	8.72	0.347	0.007
40	8.48	0.337	0.014
60	8.28	0.329	0.021
80	8.10	0.322	0.027
100	7.95	0.316	0.033
150	7.64	0.304	0.048
200	7.39	0.294	0.062
300	7.01	0.279	0.088
400	6.71	0.267	0.112
500	6.48	0.258	0.135
600	6.28	0.250	0.157
700	6.11	0.243	0.178
730	6.07	0.241	0.185
800	5.97	0.237	0.199
900	5.83	0.232	0.219
1000	5.71	0.227	0.238
1100	5.61	0.223	0.257
1200	5.51	0.219	0.275
1300	5.41	0.215	0.293
1400	5.33	0.212	0.311
1500	5.25	0.209	0.328
1600	5.17	0.206	0.345
1700	5.10	0.203	0.361
1800	5.04	0.200	0.378
1900	4.97	0.198	0.394
2000	4.91	0.195	0.409
2200	4.80	0.191	0.440
2400	4.70	0.187	0.470
2500	4.65	0.185	0.484

每分钟转速 R.p.m. n [min ⁻¹]	F _{Uspez} F _{Uspec} [N/cm]	M _{spez} M _{spec} [Ncm/cm]	P _{spez} P _{spec} [W/cm]
2600	4.60	0.183	0.499
2800	4.51	0.180	0.527
2880	4.48	0.178	0.538
3000	4.43	0.176	0.554
3200	4.36	0.173	0.581
3400	4.28	0.170	0.607
3600	4.22	0.168	0.632
3800	4.15	0.165	0.657
4000	4.09	0.163	0.682
4500	3.95	0.157	0.740
5000	3.82	0.152	0.796
5500	3.71	0.148	0.850
6000	3.60	0.143	0.901
6500	3.51	0.140	0.950
7000	3.42	0.136	0.997
7500	3.33	0.133	1.042
8000	3.26	0.130	1.086
8500	3.18	0.127	1.128
9000	3.11	0.124	1.168
9500	3.05	0.121	1.207
10000	2.99	0.119	1.245
12000	2.77	0.110	1.384
15000	2.50	0.099	1.561
18000	2.28	0.091	1.708
20000	2.15	0.086	1.791

转速超过每分钟20000转和/或带速超过80m/s时, 需要对传输装置进行特殊设计。请咨询我公司。

Rotational speeds over 20000 rpm and/or belt speeds over 80 m/s need special drive designs. Please ask our advice.

2. 抗拉层强度 (皮带允许张力 F_{zul})、带重

Tension member strength (permitted tensile force of the belt F_{zul}). Belt weight

带宽 Belt width	b	[mm]	4	6	10	16	25	32
抗拉层强度 Tension member strength	F _{zul}	[N]	39	65	117	195	312	403
带重 Belt weight	T 2	[kg/m]	0.006	0.009	0.015	0.024	0.038	0.048
	T 2.5-DL	[kg/m]	0.006	0.009	0.016	0.025	0.040	0.051

3. 挠性 (最低齿数、最小直径)

Flexibility (Minimum numbers of teeth, minimum diameter)

无反向弯曲 without contraflexure		同步带轮 Timing pulley	Z _{min}	10
		张紧轮 (光面), 在凸齿轮上运转 Tension roller (smooth), running on teeth	d _{min} [mm]	15
有反向弯曲 with contraflexure		同步带轮 Timing pulley	Z _{min}	18
		张紧轮 (光面), 在皮带背面运转 Tension roller (smooth), running on the back of the belt	d _{min} [mm]	15

T 型同步带

T 5/T 5-DL

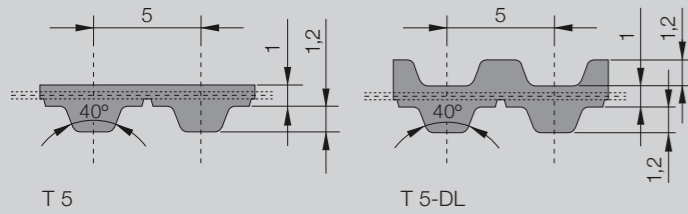

CONTI® SYNCHROFLEX 同步带 (SFX) T 5/T 5-DL

按照 DIN 7721 确定的公制节距和梯形齿的标准 T 齿型。

- 可用版本:
- 单面 (als Standard)
 - “E” 抗拉层, 挠性更好
 - 酰胺抗拉层
 - 可按客户需求采用特殊聚氨酯材料
 - 防静电、颜色可选、可机械加工

DL: 双面
FA: 背面较厚
FN: 皮带背面的齿型

CONTI® SYNCHROFLEX Timing Belt (SFX) T 5/T 5-DL

Standard T profile according to DIN 7721 with metric pitch and trapezoidal teeth.

- Available versions:
- single-sided (as standard)
 - with “E” tension member for a better flexibility
 - with Aramid tension member
 - polyurethane special materials upon request
 - antistatic, coloured, mechanical reworked

DL: double-sided
FA: with bigger back thickness
FN: with profiles on the back of the belt

订购实例 Order example

CONTI® SYNCHROFLEX 同步带
CONTI® SYNCHROFLEX® Timing Belt

带宽 (单位: mm) Belt width in mm 10 T5/455

类型/节距 Typ/Pitch _____

带长 (单位: mm) Belt length in mm _____

类型 / 长度* Type / Length*	齿数 Number of teeth	类型 / 长度* Type / Length*	齿数 Number of teeth
T 5 / 100	20	T 5 / 610	122
T 5 / 150	30	T 5 / 615 FN	123
T 5 / 150 DL	30	T 5 / 620	124
T 5 / 165	33	T 5 / 620 DL	124
T 5 / 165 FN33	33	T 5 / 625 DL	125
T 5 / 180	36	T 5 / 630	126
T 5 / 185	37	T 5 / 630 FA	126
T 5 / 200	40	T 5 / 650	130
T 5 / 210	42	T 5 / 650 FA	130
T 5 / 215	43	T 5 / 660	132
T 5 / 220	44	T 5 / 660 FN30	132
T 5 / 225	45	T 5 / 690	138
T 5 / 225 FN90	45	T 5 / 690 FA	138
T 5 / 245	49	T 5 / 690 FN3	138
T 5 / 250	50	T 5 / 700	140
T 5 / 255	51	T 5 / 720	144
T 5 / 260	52	T 5 / 725	145
T 5 / 260 DL	52	T 5 / 750	150
T 5 / 260 FN1	52	T 5 / 750 DL	150
T 5 / 270	54	T 5 / 750 FN2	150
T 5 / 280	56	T 5 / 750 FN4	150
T 5 / 295	59	T 5 / 765	153
T 5 / 300 DL	60	T 5 / 780	156
T 5 / 305	61	T 5 / 800	160
T 5 / 330	66	T 5 / 800 FN2	160
T 5 / 330 DL	66	T 5 / 815	163
T 5 / 340	68	T 5 / 815 DL	163
T 5 / 340 FN6	68	T 5 / 840	168
T 5 / 355	71	T 5 / 840 FN138	168
T 5 / 365	73	T 5 / 840 FN84	168
T 5 / 390	78	T 5 / 860 FN1	172
T 5 / 390 FN1	78	T 5 / 860 DL	172
T 5 / 400	80	T 5 / 900	180
T 5 / 410	82	T 5 / 920	184
T 5 / 410 DL	82	T 5 / 925 FN1	185
T 5 / 420	84	T 5 / 940	188
T 5 / 455	91	T 5 / 940 DL	188
T 5 / 460	92	T 5 / 990	198
T 5 / 460 FN4	92	T 5 / 990 FN4	198
T 5 / 460 DL	92	T 5 / 1075	215
T 5 / 480	96	T 5 / 1075 FA	215
T 5 / 500	100	T 5 / 1100	220
T 5 / 500 FN10	100	T 5 / 1100 DL	220
T 5 / 505	101	T 5 / 1100 FN22	220
T 5 / 510	102	T 5 / 1140 FN1	228
T 5 / 510 FN1	102	T 5 / 1160	232
T 5 / 510 FN84	102	T 5 / 1215	243
T 5 / 515 DL	103	T 5 / 1215 FN1	243
T 5 / 525	105	T 5 / 1215 FN54	243
T 5 / 525 FA	105	T 5 / 1315	263
T 5 / 525 DL	105	T 5 / 1325 DL	265
T 5 / 545	109	T 5 / 1350 FN1	270
T 5 / 550	110	T 5 / 1380	276
T 5 / 560	112	T 5 / 1380 FN1	276
T 5 / 575	115	T 5 / 1500	300
T 5 / 590	118		
T 5 / 590 DL	118		
T 5 / 600 FN24	120		
T 5 / 600 FN25	120		
T 5 / 600 FN30	120		

首选带宽*

Preferred belt width*

in mm: 6, 10, 16, 25, 50

* 可按客户要求提供其他尺寸。
* Other dimensions upon request.

T standard Timing Belts

技术数据 Technical data

1. 凸齿抗剪强度 (单位带齿强度) Tooth shear strength (specific belt tooth strength)

每分钟转速 R.p.m. n [min ⁻¹]	F _{Uspez} F _{Uspec} [N/cm]	M _{spez} M _{spec} [Ncm/cm]	P _{spez} P _{spec} [W/cm]
0	24.00	1.910	0.000
20	23.40	1.861	0.039
40	22.90	1.819	0.076
60	22.40	1.783	0.112
80	22.00	1.751	0.147
100	21.70	1.723	0.180
200	20.30	1.614	0.338
300	19.30	1.536	0.483
400	18.55	1.476	0.618
500	17.93	1.427	0.747
600	17.41	1.385	0.870
700	16.96	1.349	0.989
800	16.56	1.318	1.104
900	16.20	1.289	1.215
1000	15.88	1.263	1.323
1100	15.58	1.240	1.428
1200	15.31	1.218	1.531
1300	15.06	1.198	1.632
1400	14.83	1.180	1.730
1500	14.61	1.162	1.826
1600	14.40	1.146	1.920
1700	14.21	1.131	2.010
1800	14.03	1.116	2.100
1900	13.85	1.102	2.190
2000	13.69	1.089	2.280
2200	13.38	1.065	2.450
2400	13.10	1.042	2.620
2600	12.84	1.021	2.780
2800	12.59	1.002	2.940
3000	12.37	0.984	3.090

每分钟转速 R.p.m. n [min ⁻¹]	F _{Uspez} F _{Uspec} [N/cm]	M _{spez} M _{spec} [Ncm/cm]	P _{spez} P _{spec} [W/cm]
3200	12.16	0.967	3.24
3400	11.96	0.951	3.39
3600	11.77	0.936	3.53
3800	11.59	0.922	3.67
4000	11.42	0.909	3.81
4500	11.03	0.878	4.14
5000	10.68	0.850	4.45
5500	10.36	0.825	4.75
6000	10.07	0.802	5.04
6500	9.81	0.780	5.31
7000	9.56	0.761	5.58
7500	9.33	0.742	5.83
8000	9.11	0.725	6.08
8500	8.91	0.709	6.31
9000	8.72	0.694	6.54
9500	8.54	0.679	6.76
10000	8.37	0.666	6.97

转速超过每分钟10000转和/或带速超过80m/s⁹¹ 需要对传动装置进行特殊设计。请咨询我公司。
Rotational speeds over 10000 rpm and/or belt speeds over 80 m/s need special drive designs. Please ask our advice.

2. 抗拉层强度 (皮带允许张力 F_{zul})、带重 Tension member strength (permitted tensile force of the belt F_{zul}), Belt weight

带宽 Belt width	b	[mm]	6	10	16	25	32	50	75	100
抗拉层强度 Tension member strength	F _{zul}	[N]	180	330	570	930	1200	1920	2940	3930
带重 Belt weight	T 5	[kg/m]	0.014	0.024	0.038	0.060	0.077	0.120	0.180	0.240
	T 5-DL	[kg/m]	0.016	0.027	0.043	0.067	0.086	0.135	0.203	0.270

3. 挠性 (最低齿数、最小直径) Flexibility (Minimum numbers of teeth, minimum diameter)

无反向弯曲 without contraflexure		同步带轮 Timing pulley	Z _{min}	12
		张紧轮 (光面), 在凸齿轮上运转 Tension roller (smooth), running on teeth	d _{min} [mm]	30
有反向弯曲 with contraflexure		同步带轮 Timing pulley	Z _{min}	15
		张紧轮 (光面), 在皮带背面运转 Tension roller (smooth), running on the back of the belt	d _{min} [mm]	30

T 型同步带

T 10/T 10-DL

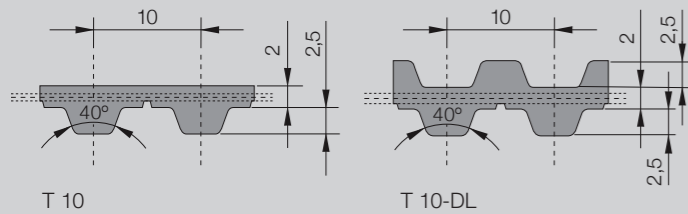

CONTI® SYNCHROFLEX 同步带 (SFX) T 10/T 10-DL

按照 DIN 7721 确定的公制节距和梯形齿的标准 T 齿型。

可用版本:

- 单面 (als Standard)
- “E” 抗拉层, 挠性更好
- 酰胺抗拉层
- 可按客户需求采用特殊聚氨酯材料
- 防静电、颜色可选、可机械加工

DL: 双面

FA: 背面较厚

FN: 皮带背面的齿型

CONTI® SYNCHROFLEX Timing Belt (SFX) T 10/T 10-DL

Standard T profile according to DIN 7721 with metric pitch and trapezoidal teeth.

Available versions:

- single-sided (as standard)
- with “E” tension member for a better flexibility
- with Aramid tension member
- polyurethane special materials upon request
- antistatic, coloured, mechanical reworked

DL: double-sided

FA: with bigger back thickness

FN: with profiles on the back of the belt

订购实例 Order example

CONTI® SYNCHROFLEX 同步带
CONTI® SYNCHROFLEX® Timing Belt

带宽 (单位: mm)
Belt width in mm 16 T10/260

类型/节距
Typ/Pitch _____

带长 (单位: mm)
Belt length in mm _____

类型 / 长度* Type / Length*	齿数 Number of teeth	类型 / 长度* Type / Length*	齿数 Number of teeth
T 10 / 260	26	T 10 / 1010	101
T 10 / 260 DL	26	T 10 / 1080	108
T 10 / 370	37	T 10 / 1110	111
T 10 / 400	40	T 10 / 1140	114
T 10 / 410	41	T 10 / 1150	115
T 10 / 410 FA	41	T 10 / 1210	121
T 10 / 420 FN21	42	T 10 / 1210 DL	121
T 10 / 440	44	T 10 / 1240	124
T 10 / 450	45	T 10 / 1240 DL	124
T 10 / 480	48	T 10 / 1250	125
T 10 / 500	50	T 10 / 1250 DL	125
T 10 / 530	53	T 10 / 1300	130
T 10 / 530 DL	53	T 10 / 1320	132
T 10 / 530 FN	53	T 10 / 1320 DL	132
T 10 / 560	56	T 10 / 1350	135
T 10 / 600	60	T 10 / 1350 DL	135
T 10 / 610	61	T 10 / 1390	139
T 10 / 630	63	T 10 / 1400	140
T 10 / 630 DL	63	T 10 / 1420	142
T 10 / 660	66	T 10 / 1420 DL	142
T 10 / 660 DL	66	T 10 / 1450	145
T 10 / 680	68	T 10 / 1460	146
T 10 / 690	69	T 10 / 1460 FN146	146
T 10 / 700	70	T 10 / 1500	150
T 10 / 720	72	T 10 / 1500 FN75	150
T 10 / 720 DL	72	T 10 / 1560	156
T 10 / 730	73	T 10 / 1610	161
T 10 / 750	75	T 10 / 1610 DL	161
T 10 / 760	76	T 10 / 1750	175
T 10 / 780	78	T 10 / 1780	178
T 10 / 780 FN78	78	T 10 / 1800 FN12	180
T 10 / 800 FN80	80	T 10 / 1880	188
T 10 / 810	81	T 10 / 1880 DL	188
T 10 / 840	84	T 10 / 1880 FN94	188
T 10 / 840 DL	84	T 10 / 1960	196
T 10 / 840 FN84	84	T 10 / 2250	225
T 10 / 850	85	T 10 / 3100	310
T 10 / 880	88	T 10 / 4780	478
T 10 / 890	89	T 10 / 4780 DL**	478
T 10 / 920	92		
T 10 / 960	96		
T 10 / 970	97		
T 10 / 970 FN97	97		
T 10 / 980	98		
T 10 / 980 DL	98		

首选带宽*

Preferred belt width*

in mm: 16, 25, 32, 50

* 可按客户要求提供其他尺寸。

** 请寻求康迪泰克传统系统有限公司的技术支持。

* Other dimensions upon request.

** Please request technical support from the ContiTech Antriebssysteme GmbH.

T standard Timing Belts

技术数据 Technical data

1. 凸齿抗剪强度 (单位带齿强度)

Tooth shear strength (specific belt tooth strength)

每分钟转速 R.p.m. n [min ⁻¹]	F _{Uspez} F _{Uspec} [N/cm]	M _{spez} M _{spec} [Ncm/cm]	P _{spez} P _{spec} [W/cm]
0	50.5	8.04	0.000
20	49.0	7.80	0.163
40	47.7	7.60	0.318
60	46.6	7.42	0.466
80	45.7	7.27	0.609
100	44.8	7.13	0.746
200	41.4	6.60	1.381
300	39.1	6.22	1.953
400	37.2	5.92	2.480
500	35.7	5.68	2.980
600	34.4	5.48	3.440
700	33.3	5.31	3.890
800	32.4	5.15	4.320
900	31.5	5.01	4.730
1000	30.7	4.89	5.120
1100	30.0	4.77	5.500
1200	29.3	4.67	5.870
1300	28.7	4.57	6.220
1400	28.2	4.48	6.570
1500	27.6	4.40	6.910
1600	27.1	4.32	7.230
1700	26.7	4.24	7.550
1800	26.2	4.17	7.860
1900	25.8	4.10	8.160
2000	25.4	4.04	8.460
2200	24.6	3.92	9.030
2400	23.9	3.81	9.580
2600	23.3	3.71	10.10
2800	22.7	3.62	10.60
3000	22.2	3.53	11.08

每分钟转速 R.p.m. n [min ⁻¹]	F _{Uspez} F _{Uspec} [N/cm]	M _{spez} M _{spec} [Ncm/cm]	P _{spez} P _{spec} [W/cm]
3200	21.70	3.45	11.55
3400	21.20	3.36	11.99
3600	20.70	3.30	12.42
3800	20.30	3.23	12.84
4000	19.86	3.16	13.24
4500	18.91	3.01	14.18
5000	18.06	2.87	15.05
5500	17.28	2.75	15.84
6000	16.58	2.64	16.58
6500	15.93	2.54	17.26
7000	15.33	2.44	17.88
7500	14.76	2.35	18.46
8000	14.24	2.27	18.99
8500	13.74	2.18	19.47
9000	13.28	2.11	19.92
9500	12.84	2.04	20.30
10000	12.42	1.97	20.70

转速超过每分钟10000转和/或带速超过60m/s时, 需要对传动装置进行特殊的设计。请咨询我公司。

Rotational speeds over 10000 rpm and/or belt speeds over 60 m/s need special drive designs. Please ask our advice.

2. 抗拉层强度 (皮带允许张力 F_{zul})、带重

Tension member strength (permitted tensile force of the belt F_{zul}). Belt weight

带宽 Belt width	b	[mm]	16	25	32	50	75	100	150
抗拉层强度 Tension member strength	F _{zul}	[N]	1200	2000	2700	4300	6600	8800	13400
带重 Belt weight	T 10	[kg/m]	0.077	0.120	0.154	0.240	0.360	0.480	0.720
	T 10-DL	[kg/m]	0.091	0.143	0.182	0.285	0.428	0.570	0.855

3. 挠性 (最低齿数、最小直径)

Flexibility (Minimum numbers of teeth, minimum diameter)

无反向弯曲 without contraflexure		同步带轮 Timing pulley	Z _{min}	12
		张紧轮 (光面), 在凸齿上运转 Tension roller (smooth), running on teeth	d _{min} [mm]	60
有反向弯曲 with contraflexure		同步带轮 Timing pulley	Z _{min}	20
		张紧轮 (光面), 在皮带背面运转 Tension roller (smooth), running on the back of the belt	d _{min} [mm]	60

T 型同步带

T standard Timing Belts

T 20/T 20-DL

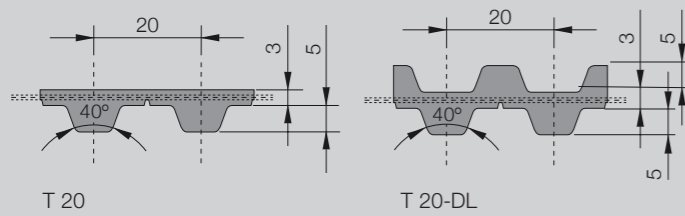

CONTI® SYNCHROFLEX 同步带 (SFX) T 20/T 20-DL

按照 DIN 7721 确定的公制节距和梯形齿的标准 T 齿型。

技术数据是指标准聚氨酯和标准钢丝绳抗拉层。

可用版本:

- 单面 (als Standard)
- “E” 抗拉层, 挠性更好
- 酰胺抗拉层 (außer DL)
- 可按客户需求采用特殊聚氨酯材料
- 防静电、着色、机械返工

DL: 双面

CONTI® SYNCHROFLEX Timing Belt (SFX) T 20/T 20-DL

Standard T profile according to DIN 7721 with metric pitch and trapezoidal teeth.

The technical data refer to standard polyurethane and standard steel cord tension members.

Available versions:

- single-sided (as standard)
- with “E” tension member for a better flexibility
- with Aramid tension member (except DL)
- polyurethane special materials upon request
- antistatic, coloured, mechanical reworked

DL: double-sided

类型 / 长度* Type / Length*	齿数 Number of teeth
T 20 / 1260	63
T 20 / 1460	73
T 20 / 1780	89
T 20 / 1880	94
T 20 / 2600	130
T 20 / 2600 DL**	130
T 20 / 2600 FN52	130
T 20 / 3100	155
T 20 / 3620	181
T 20 / 3620 DL**	181

首选带宽* (单位: mm):

Preferred belt width* in mm:

32, 50, 75, 100

* 可按客户要求提供其他尺寸。

** 要减小带轮的中心距, 请寻求销售合作伙伴的技术支持。

* Other dimensions upon request.

** In combination with reduced pulley gap please ask for technical support from your sales partner.

技术数据 Technical data

1. 凸齿抗剪强度 (单位带齿强度)

Tooth shear strength (specific belt tooth strength)

每分钟转速 R.p.m. n [min ⁻¹]	F_{Uspez} F_{Uspec} [N/cm]	M_{spez} M_{spec} [Ncm/cm]	P_{spez} P_{spec} [W/cm]
0	101.5	32.30	0.000
20	98.1	31.20	0.654
40	95.3	30.30	1.271
60	92.8	29.50	1.856
80	90.7	28.90	2.420
100	88.7	28.20	2.960
200	81.2	25.90	5.420
300	75.9	24.20	7.590
400	71.8	22.90	9.570
500	68.4	21.80	11.410
600	65.6	20.90	13.110
700	63.1	20.10	14.730
800	60.9	19.40	16.250
900	59.0	18.78	17.700
1000	57.2	18.22	19.080
1100	55.6	17.71	20.400
1200	54.2	17.24	21.700
1300	52.8	16.80	22.900
1400	51.5	16.40	24.000
1500	50.3	16.02	25.200
1600	49.2	15.66	26.200
1700	48.2	15.33	27.300
1800	47.2	15.01	28.300
1900	46.2	14.71	29.300
2000	45.3	14.42	30.200
2200	43.6	13.89	32.000
2400	42.1	13.40	33.700
2600	40.7	12.95	35.200
2800	39.4	12.53	36.700
3000	38.1	12.13	38.100

每分钟转速 R.p.m. n [min ⁻¹]	F_{Uspez} F_{Uspec} [N/cm]	M_{spez} M_{spec} [Ncm/cm]	P_{spez} P_{spec} [W/cm]
3200	37.0	11.77	39.4
3400	35.9	11.42	40.7
3600	34.9	11.09	41.8
3800	33.9	10.78	42.9
4000	33.0	10.49	43.9
4500	30.8	9.81	46.2
5000	28.9	9.21	48.2
5500	27.2	8.66	49.9
6000	25.6	8.16	51.2
6500	24.2	7.69	52.4

转速超过每分钟6500转和/或带速超过40m/s时, 需要对传动装置进行特殊设计。请咨询我公司。

Rotational speeds over 6500 rpm and/or belt speeds over 40 m/s need special drive designs. Please ask our advice.

2. 抗拉层强度 (皮带允许张力 F_{zul})、带重

Tension member strength (permitted tensile force of the belt F_{zul}). Belt weight

带宽	Belt width	b	[mm]	32	50	75	100	150
抗拉层强度	Tension member strength	F_{zul}	[N]	4750	7750	12000	16000	24500
带重	Belt weight	T 20	[kg/m]	0.269	0.420	0.630	0.840	1.260
		T 20-DL	[kg/m]	0.355	0.555	0.833	1.110	1.665

3. 挠性 (最低齿数、最小直径)

Flexibility (Minimum numbers of teeth, minimum diameter)

无反向弯曲 without contraflexure		同步带轮 Timing pulley	z_{min}	15
		张紧轮 (光面), 在凸齿轮上运转 Tension roller (smooth), running on teeth	d_{min} [mm]	120
有反向弯曲 with contraflexure		同步带轮 Timing pulley	z_{min}	25
		张紧轮 (光面), 在皮带背面运转 Tension roller (smooth), running on the back of the belt	d_{min} [mm]	120

订购实例 Order example

CONTI® SYNCHROFLEX 同步带
CONTI® SYNCHROFLEX® Timing Belt

带宽 (单位: mm)
Belt width in mm

类型/节距
Typ/Pitch

带长 (单位: mm)
Belt length in mm

50 T 20/2600

英制同步带

M (MXL)

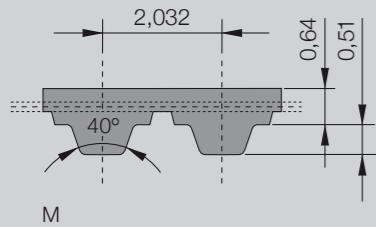

CONTI® SYNCHROFLEX 同步带 (SFX) M (MXL)

按照 DIN/ISO 5296 确定的标准梯形齿，最小节距为 2.032mm (0.08英寸)。

技术数据是指标准聚氨酯和标准钢丝绳抗拉层。

可用版本:

- 单面
- 酰胺抗拉层
- 可按客户需求采用特殊聚氨酯材料
- 抗静电、着色、机械返工

FA: 背面较厚

FN: 皮带背面的齿型

CONTI® SYNCHROFLEX Timing Belt (SFX) M (MXL)

Standard trapezoidal teeth according to DIN/ISO 5296 with Minipitch (2.032 mm = 0.08 Inch)

The technical data refer to standard polyurethane and standard steel cord tension members.

Available versions:

- single-sided
- with Aramid tension member
- polyurethane special materials upon request
- antistatic, coloured, mechanical reworked

FA: with bigger back thickness

FN: with profiles on the back of the belt

订购实例 Order example

CONTI® SYNCHROFLEX 同步带
CONTI® SYNCHROFLEX® Timing Belt

带宽 (单位: mm)
Belt width in mm 6 M/182

类型/节距
Typ/Pitch _____

带长 (单位: mm)
Belt length in mm _____

类型 Type	/ 长度 / Length*	齿数 Number of teeth
M 111/	111.76	55
M 113/	113.79	56
M 121/	121.92	60
M 121/	121.92 FA	60
M 132/	132.08	65
M 142/	142.24	70
M 144/	144.27	71
M 162/	162.56	80
M 182/	182.88	90
M 197/	197.10	97
M 203/	203.20	100
M 209/	209.30	103
M 213/	213.36	105
M 243/	243.84	120
M 256/	256.03	126
M 264/	264.16	130
M 284/	284.48	140
M 304/	304.80	150
M 355/	355.60	175
M 373/	373.89	184
M 449/	449.07	221
M 503/	503.94	248
M 508/	508.00 FN50	250
M 508/	508.00 FN80	250
M 520/	520.19	256
M 599/	599.44	295
M 731/	731.52	360
M 1178/	1178.56	580

首选带宽* (单位: mm):
Preferred belt width* in mm:

4, 6, 10

* 可按客户要求提供其他尺寸。

* Other dimensions upon request.

Imperial Timing Belts

技术数据 Technical data

1. 凸齿抗剪强度 (单位带齿强度)

Tooth shear strength (specific belt tooth strength)

每分钟转速 R.p.m. n [min ⁻¹]	F _{Uspez} F _{Uspec} [N/cm]	M _{spez} M _{spec} [Ncm/cm]	P _{spez} P _{spec} [W/cm]
0	6.58	0.209	0.000
20	6.36	0.202	0.004
40	6.18	0.197	0.008
60	6.03	0.192	0.012
80	5.90	0.188	0.016
100	5.79	0.184	0.019
150	5.56	0.177	0.028
200	5.38	0.171	0.036
300	5.10	0.162	0.051
400	4.89	0.156	0.065
500	4.72	0.150	0.079
600	4.58	0.146	0.092
700	4.45	0.142	0.104
730	4.42	0.141	0.108
800	4.35	0.138	0.116
900	4.25	0.135	0.127
1000	4.16	0.132	0.139
1100	4.08	0.130	0.150
1200	4.01	0.128	0.160
1300	3.94	0.125	0.171
1400	3.88	0.124	0.181
1460	3.85	0.123	0.187
1500	3.82	0.122	0.191
1600	3.77	0.120	0.201
1700	3.72	0.118	0.211
1800	3.67	0.117	0.220
1900	3.62	0.115	0.229
2000	3.58	0.114	0.239
2200	3.50	0.111	0.257
2400	3.42	0.109	0.274

每分钟转速 R.p.m. n [min ⁻¹]	F _{Uspez} F _{Uspec} [N/cm]	M _{spez} M _{spec} [Ncm/cm]	P _{spez} P _{spec} [W/cm]
2500	3.39	0.108	0.282
2600	3.35	0.107	0.290
2800	3.29	0.105	0.307
2880	3.26	0.104	0.313
3000	3.23	0.103	0.323
3200	3.17	0.101	0.338
3400	3.12	0.099	0.354
3600	3.07	0.098	0.368
3800	3.02	0.096	0.383
4000	2.98	0.095	0.397
4500	2.88	0.092	0.432
5000	2.78	0.088	0.463
5500	2.70	0.086	0.495
6000	2.63	0.084	0.526
6500	2.56	0.081	0.555
7000	2.49	0.079	0.581
7500	2.43	0.077	0.607
8000	2.37	0.075	0.632
8500	2.32	0.074	0.657
9000	2.27	0.072	0.681
9500	2.22	0.071	0.703
10000	2.18	0.069	0.727
12000	2.02	0.064	0.808
15000	1.82	0.058	0.910
18000	1.66	0.053	0.996
20000	1.57	0.050	1.047

转速超过每分钟20000转和/或带速超过80m/s时, 需要对传动装置进行特殊设计。请咨询我公司。

Rotational speeds over 20000 rpm and/or belt speeds over 80 m/s need special drive designs. Please ask our advice.

2. 抗拉层强度 (皮带允许张力 F_{zul})、带重

Tension member strength (permitted tensile force of the belt F_{zul}). Belt weight

带宽	Belt width	b	[mm]	4	6	10	16	25	32
抗拉层强度	Tension member strength	F _{zul}	[N]	39	65	117	195	312	403
带重	Belt weight	M	[kg/m]	0.005	0.007	0.012	0.019	0.030	0.038

3. 挠性 (最低齿数、最小直径)

Flexibility (Minimum numbers of teeth, minimum diameter)

无反向弯曲 without contraflexure		同步带轮 Timing pulley	Z _{min}	10
		张紧轮 (光面), 在凸齿轮上运转 Tension roller (smooth), running on teeth	d _{min} [mm]	15
有反向弯曲 with contraflexure		同步带轮 Timing pulley	Z _{min}	18
		张紧轮 (光面), 在皮带背面运转 Tension roller (smooth), running on the back of the belt	d _{min} [mm]	15

锯齿型同步带

K 1/K 1.5

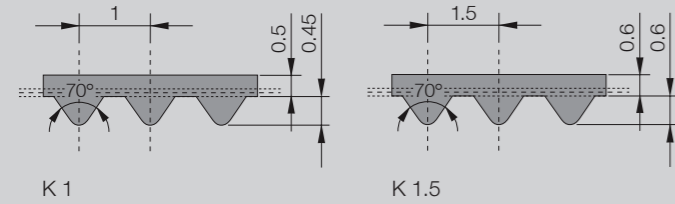

CONTI® SYNCHROFLEX 同步带 (SFX) K 1/K 1.5

型锯齿状公制节距齿型。

技术数据是指标准聚氨酯和标准钢丝绳抗拉层。

可用版本:

- 单面
- 酰胺抗拉层
- 可按客户需求采用特殊聚氨酯材料
- 抗静电、着色、机械返工

CONTI® SYNCHROFLEX Timing Belt (SFX) K 1/K 1.5

Notched profile with a metric pitch.

The technical data refer to standard polyurethane and standard steel cord tension members.

Available versions:

- single-sided
- with Aramid tension member
- polyurethane special materials upon request
- antistatic, coloured, mechanical reworked

订购实例 Order example

CONTI® SYNCHROFLEX 同步带
CONTI® SYNCHROFLEX® Timing Belt

带宽 (单位: mm)
Belt width in mm 6 K 1.5/100,5

类型/节距
Typ/Pitch _____

带长 (单位: mm)
Belt length in mm _____

Serrated Profile Timing Belts

技术数据 Technical data

1. 凸齿抗剪强度 (单位带齿强度)

Tooth shear strength (specific belt tooth strength)

类型 Type	/ 长度 / Length*	齿数 Number of teeth
K 1	/ 279.0	279
K 1	/ 348.0	348
K 1.5	/ 57.0 **	38
K 1.5	/ 64.5 **	43
K 1.5	/ 100.5	67
K 1.5	/ 141.0	94
K 1.5	/ 165.0	110
K 1.5	/ 201.0	134
K 1.5	/ 228.0	152
K 1.5	/ 286.0	191
K 1.5	/ 300.0	200
K 1.5	/ 400.5	267
K 1.5	/ 501.0	334
K 1.5	/ 600.0	400
K 1.5	/ 1242.5	828
K 1.5	/ 1671.5	1114

首选带宽* (单位: mm):

Preferred belt width* in mm:

4, 6, 10

* 可按客户要求提供其他尺寸。

** In Gießpolyurethan 93 ShA, Farbe: rot.

* Other dimensions upon request.

** in casting polyurethane 93 ShA, red colour.

每分钟转速 R.p.m. n [min ⁻¹]	F _{Uspez} F _{Uspec} [N/cm]	M _{spez} M _{spec} [Ncm/cm]	P _{spez} P _{spec} [W/cm]
0	6.45	0.154	0.000
20	6.23	0.149	0.003
40	6.06	0.145	0.006
60	5.91	0.141	0.009
80	5.79	0.138	0.012
100	5.68	0.136	0.014
150	5.46	0.130	0.020
200	5.28	0.126	0.026
300	5.00	0.119	0.037
400	4.80	0.115	0.048
500	4.63	0.111	0.058
600	4.49	0.107	0.067
700	4.37	0.104	0.076
730	4.33	0.103	0.079
800	4.26	0.102	0.085
900	4.17	0.100	0.094
1000	4.08	0.097	0.102
1100	4.00	0.095	0.110
1200	3.93	0.094	0.118
1300	3.87	0.092	0.126
1400	3.81	0.091	0.133
1460	3.77	0.090	0.138
1500	3.75	0.090	0.141
1600	3.69	0.088	0.148
1700	3.64	0.087	0.155
1800	3.60	0.086	0.162
1900	3.55	0.085	0.169
2000	3.51	0.084	0.175
2200	3.43	0.082	0.189
2400	3.35	0.080	0.201

每分钟转速 R.p.m. n [min ⁻¹]	F _{Uspez} F _{Uspec} [N/cm]	M _{spez} M _{spec} [Ncm/cm]	P _{spez} P _{spec} [W/cm]
2500	3.32	0.079	0.207
2600	3.29	0.079	0.214
2800	3.22	0.077	0.225
2880	3.20	0.076	0.230
3000	3.17	0.076	0.238
3200	3.11	0.074	0.249
3400	3.06	0.073	0.260
3600	3.01	0.072	0.271
3800	2.96	0.071	0.281
4000	2.92	0.070	0.292
4500	2.82	0.067	0.317
5000	2.73	0.065	0.341
5500	2.65	0.063	0.364
6000	2.57	0.061	0.385
6500	2.51	0.060	0.408
7000	2.44	0.058	0.427
7500	2.38	0.057	0.446
8000	2.33	0.056	0.466
8500	2.27	0.054	0.482
9000	2.22	0.053	0.499
9500	2.18	0.052	0.518
10000	2.13	0.051	0.532
12000	1.98	0.047	0.594
15000	1.78	0.042	0.667
18000	1.63	0.039	0.733
20000	1.54	0.037	0.770

转速超过每分钟20000转和/或带速超过80m/s时, 需要对传动装置进行特殊设计。请咨询我公司。

Rotational speeds over 20000 rpm and/or belt speeds over 80 m/s need special drive designs. Please ask our advice.

2. 抗拉层强度 (皮带允许张力 F_{zul})、带重

Tension member strength (permitted tensile force of the belt F_{zul}). Belt weight

带宽	Belt width	b	[mm]	4	6	10	16	25	32
抗拉层强度	Tension member strength	F _{zul}	[N]	39	65	117	195	312	403
带重	Belt weight	K 1	[kg/m]	0.0044	0.007	0.011	0.018	0.028	0.035
		K 1.5	[kg/m]	0.004	0.006	0.010	0.016	0.025	0.032

3. 挠性 (最低齿数、最小直径)

Flexibility (Minimum numbers of teeth, minimum diameter)

无反向弯曲 without contraflexure		同步带轮 Timing pulley	Z _{min}	16
		张紧轮 (光面), 在凸齿轮上运转 Tension roller (smooth), running on teeth	d _{min} [mm]	15
有反向弯曲 with contraflexure		同步带轮 Timing pulley	Z _{min}	20
		张紧轮 (光面), 在皮带背面运转 Tension roller (smooth), running on the back of the belt	d _{min} [mm]	15

