

AMT6132

3D Omnipolar Low-Power Hall-Effect IC

Product Feature

- Ultra high sensitivity with typically Bop 20 Gs
- Micro-power consumption ideal for battery power applications
- Input voltage range of 2.2V~ 5 V
- No need Pull-up Resistor

Application Scenario

- Smart meter
- Cover switch
- Contactless switch
- Stroke sensing

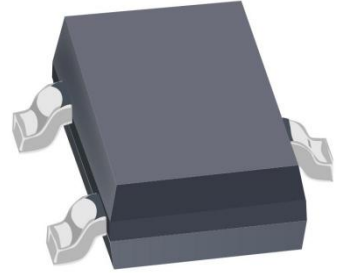

Function Description

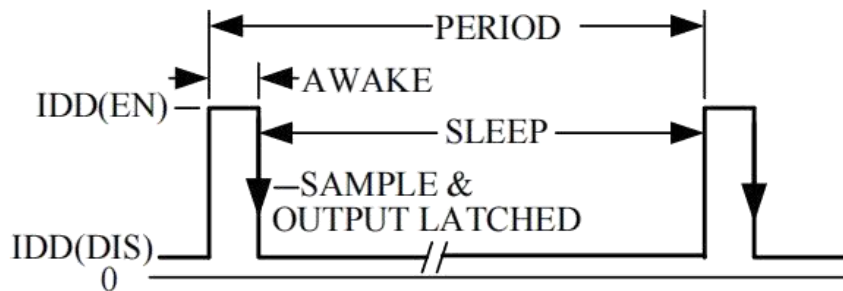

AMT6132 is designed for low power, high performance omnipolar detection hall-effect IC, integrated an on-chip hall voltage generator for magnetic sensing.

Internal timing circuitry activates the sensor for 50 μ s and deactivates it for the remainder of the period (100ms). A short "awake" time allows for stabilization prior to the sensor sampling and data latching on the falling edge of the timing pulse. The output during the "sleep" time is latched in the IMSt sampled state. The supply current is not affected by the output state.

Functional Block Diagram

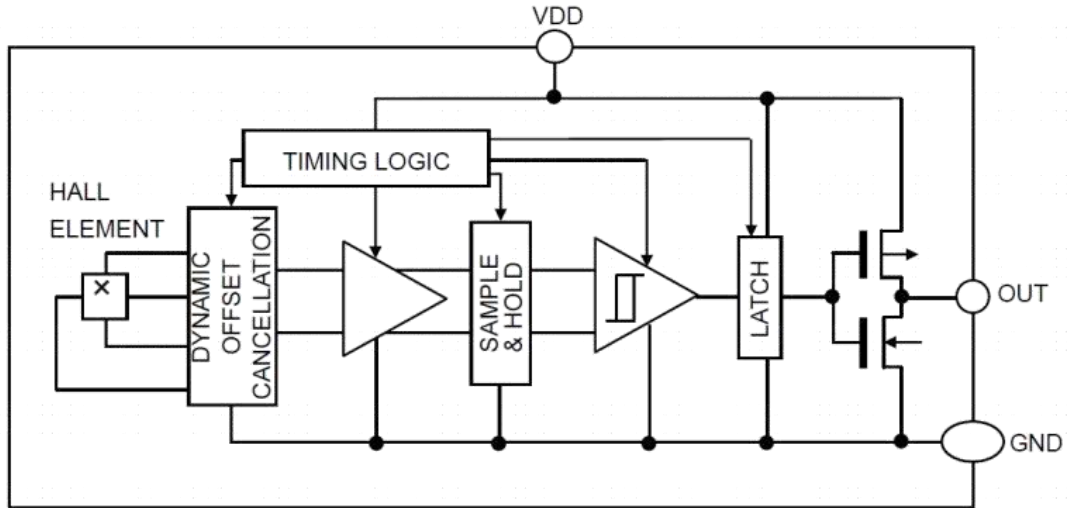

Typical Application Circuit

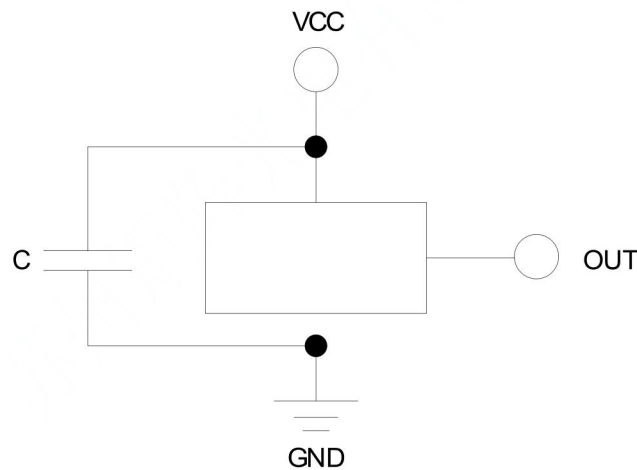

AMT6132's pole-independent sensing technique allows for operation with either a north or south poles magnet orientation, enhancing the manufacturability of the device. The state-of-the-art technology provides the same output polarity for either pole face.

C serves two purposes: minimizing ripples on the input voltage and enhancing immunity from RF transmission noises within close proximity. Recommended values are between 10nF and 100nF. The larger the capacitance, the better the noise immunity is for the AMT6132.

Package Outline Drawing(Unit MM)

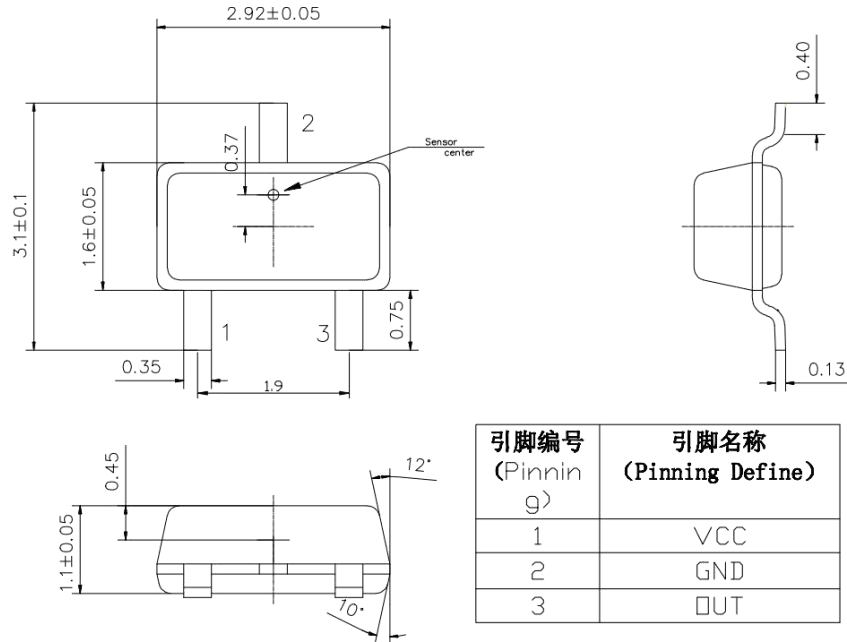

Absolute Maximum Rating

Parameter	Symbol	Limit	Unit
Power Supply Voltage	VCC	-0.3~5	V
Operating Temperature	Topr	-40~150	°C
ESD(HBM)	ESD	8000	V

Note:Stresses beyond the limit listed in “Absolute Maximum Rating” may cause permanent damage to the device.

**Operating Parameters**

Parameter	Symbol	Min	Max	Unit
Power Supply Voltage	VCC	2.2	5	V
Operating Temperature	Topr	-40	85	°C

Magnetic Characteristic

VCC=2.8V, Topr=25°C, unless otherwise specified. 1mT=10Gs

Parameter	Symbol	Min	Type	Max	Unit
Z-axis BOP (N/S)	Bop	7	-	15	Gs
Z-axis BRP (N/S)	Brp	5	-	10	Gs
Z-axis Hys (N/S)	Bhys	-	5	-	Gs
X,Y-axis BOP (N/S)	Bop	-	20	50	Gs
X,Y-axis BRP (N/S)	Brp	10	-	30	Gs
X,Y-axis Hys (N/S)	Bhys	-	10	-	Gs

Electrical Characteristics

VCC=2.8V, Topr=25°C, unless otherwise specified. 1mT=10Gs

Parameter	Symbol	Conditions	Min	Type	Max	Unit
Power Supply Voltage	VCC	Operating	2.2	2.8	5	V
Supply Current	IDD	VCC=2.2V, Ta=-40~85°C	-	3	10	μA
Awake Time	Tawake		-	50	100	μs
Period	Tperiod		-	100	150	ms
Duty Cycle	D.C.		-	0.05	-	%
Output Off Voltage(High)	Voh	Iout=+1mA	Vdd-0.3	Vdd-0.1	Vdd+0.3	V
Output On Voltage(Low)	Vol	Iout=-1mA	-0.3	0.1	0.3	V

Latch-Type Operating Characteristics

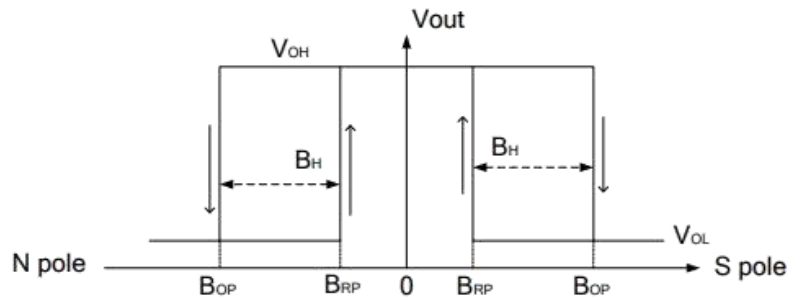
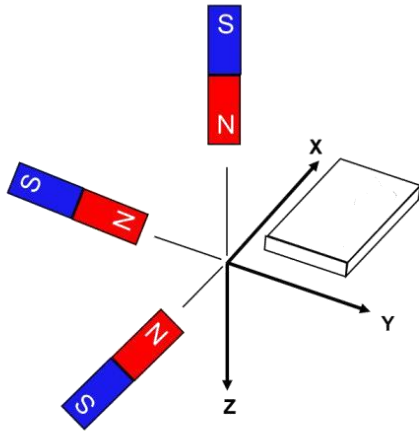

Reliability Test Terms

No.	Terms	Conditions	Duration
1	High Temperature Storage	150±5°C	1000hr
2	High Temperature Oxidation	120°C/1V	1000hr
3	Low Temperature Oxidation	-40°C/6mA	1000hr
4	Temperature and Humidity Storage Oxidation	85°C/85%RH/9mA	1000hr
5	Temperature and Humidity Storage	85°C/85%RH	1000hr
6	Pressure Cooker Test	121°C/100%RH/2atm	24hr
7	Temperature Cycling Test	-55°C(30min)~25°C(5min)~150°C(30min)	30cycle

Packaging and Storage Methods

1. Packing specification

Product	Package	Marking ID	Packing Type	Quantity
AMT6132	SOT23-3	Wafer ID	Bag	3000pcs

2. Storage method

2.1 The product should be stored in an appropriate temperature and humidity Environment (5 to 35°C, 40% to 85%RH).

2.2 Even under appropriate conditions, long-term storage may lead to the decrease of solderability and electrical properties of products. For products stored for a long time, the weldability should be checked before use.

2.3 If it is stored for more than 2 years, it is recommended to store it in a nitrogen environment.

Oxygen in the atmosphere will oxidize the lead of the product, resulting in poor solderability of the lead.

Safety Protection and Precautions

1. This product is sensitive to ESD (electrostatic discharge). When contacting Hall elements marked with ESD-Caution, the environmental requirements are as follows:

1.1 Electrostatic charges are unlikely to occur in the environment (for example, the relative humidity exceeds 40%RH).

1.2 Wear anti-static clothing and wrist strap when touching products.

1.3 Implement anti-static measures for equipment or containers that are in direct contact with products.

2. Do not turn the product into gas, powder or liquid by burning, crushing or chemical treatment.

3. Please abide by the laws and company regulations when discarding this product.